

*Sistemas
de barandales
modulares*

VARIEDAD
EN
HERRAJES
TOLUCA



HERRALUM[®]
líder en herrajes para aluminio y vidrio



comenza
Railing Passion

GLOSARIO

Ref.	Descripción
	Pegamento
	Atornillar
	Accesorio para soldar
	Atornillar con llave allen
	Llave allen corta
	Llave gancho
	Llave pitones
	Llave hexagonal
	Adjusting Wedge Tool
	Rodillo
	Cutter
	Cinta de doble cara
	SP-101
	Acabado Satinado
	Acabado gris plata

Ref.	Descripción
E	Espesor
G	Espesor del cristal
L/R	Izquierda/derecha
M	Métrica del tornillo
	Piezas por caja
LG	Largo
Ø A	Diámetro del tubo 1
Ø B	Diámetro del tubo 2
Ø	Diámetro
Ref	Referencia
RE	Regulable

VARIEDAD
EN
HERRAJES

TOLUCA

ÍNDICE

<p>COMENZA 06</p> <p>02 Glosario</p> <p>03 Índice</p> <p>04 Índice por referencias</p> <p>06 Comenza Railing Passion</p>	<p>GLASSFIT 08</p> <p>08 GlassFit SV-1.301: Top</p> <p>14 GlassFit SV-1.302: Side</p> <p>18 Sistema de pinzas vidrio para suelo</p> <p>22 Pinza lateral</p> <p>26 Adaptador lateral vidrio</p> <p>30 Tubo y accesorios en U</p> <p>32 Pasamanos redondo en inox</p> <p>34 Pinzas de unión</p>	<p>R-CONCEPT 36</p> <p>37 Bases suelo, bases pared y embellecedores</p> <p>39 Bases laterales</p> <p>40 Conectores grapas</p> <p>41 Barillas</p> <p>42 Easy cable</p> <p>44 Soportes pasamanos</p> <p>45 Tapones y remates finales</p> <p>46 Codos y conectores de tubo</p>
<p>HANDRAIL 48</p> <p>49 Soporte pasamanos pared</p>	<p>BRICO 50</p> <p>51 Adhesivos, limpieza y mantenimiento</p> <p>52 Tornillería y remaches</p> <p>53 Herramientas y consumibles</p>	<p>INFO 55</p> <p>55 Info</p>

ÍNDICE POR REFERENCIAS

CLAVE HERRALUM	CLAVE COMENZA	Página
1380001200SA	AV-601	33-37
1380035112SA	AV-602	37
1380035200SA		
1380002112SA	AV-603	37
1380002200SA		
1380049SA	AV-609	30
1380029SA	CC-700	40
1380030SA		
1380031112SA	CC-701	40
1380031200SA		
1380032112SA		
1380032200SA		
1380010SA	CC-724	40
1380011200SA	CC-725	40
1380055SA	CC-736	34
1380056SA	CC-737	34
1380044SA	CC-772	27
1380045030SA	CC-775 D.30	29
1380017SA	CC-775 D.50	28
1380022SA	CC-780	20
1380042SA	CC-781	19
1380043SA	CC-791	23
1380003112SA	CT-200	32-46
1380003200SA		
1380004112SA	CT-201	46
1380004200SA		
1380005112SA	CT-202	47
1380005200SA		
1380006112SA	CT-207	33-47
1380006200SA		
1380051SA	CT-211	31
1380052SA	CT-212	31
1380048500NE	PL-03	30
138003800	PL-11	9-14
1380039NA	PM-24	11
1380040NA	PM-25	11
1380041NA	PM-26	11
1380057NA	PM-29	16
1380058NA	PM-30	16
1380060250NA	PM-52	17
1380047500SA	RP-1400	30
138002700	RP-1460	42
1380008112SA	SA-404	44

CLAVE HERRALUM	CLAVE COMENZA	Página
1380008200SA	SA-404	44
1380007012SA	SA-406	33-46
1380007112SA		
1380007200SA		
1380046112SA	SA-409	46
1380053SA	SA-416	31
1380054SA	SA-417	31
1380012200SA	SA-420 (BG-R)	44
1380028200SA	SA-423 (BG-R)	32
1380013112SA	SA-451	38
1380013200SA		
1380025SA	SC-800	42
1380026SA	SC-801	42
1380015112SA	SL-1120	39
1380015200SA		
1380016200SA	ST-314	32
1380014112SA	ST-320	41
1380014200SA		
1380023112SA	ST-322	41
1380023200SA		
1380024112SA		
1380024200SA		
1380037200SA	ST-353	49
1380250012NA	SV-1301-1	9
1380059250NA	SV-1302-2	14
1380009012SA	TF-502	33-45
1380009112SA		
1380009200SA		
1380036112SA	TF-505	45
1380036200SA		
1380050SA	TF-512	30
138010000	FAST-FIX GLUE (A+B) 50+50ml	51
138010100	CLEAN + (500ml)	51
138010200	STAIN ZERO (500ml)	51
138001800	BR-2011	52
138001900		
138002000	DIN-7991	52
138002100	DIN-912	52
138010400	BR-2030	28-53
138010500	BR-2031	19-20-53
138010600	BR-2039	10-15
138010700	BR-2041	10-15
138010300	TR-308	53
2251018012SA	- - - - -	32-37
2251018112SA		
2251018200SA		

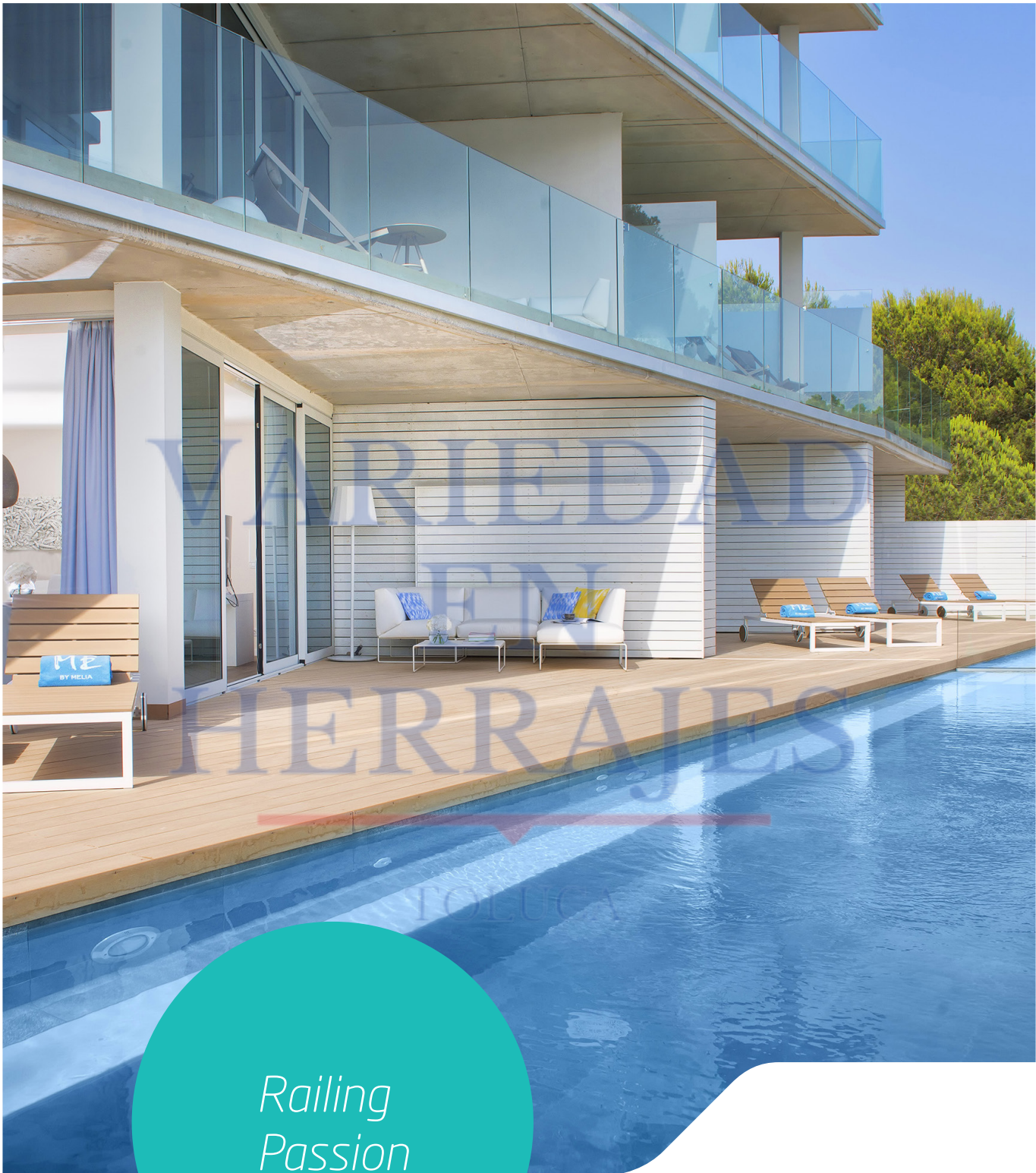

*Railing
Passion*



Pasión por la seguridad



Pasión por las personas

VARIEDAD
EN
HERRAJES

TOLUCA

COMENZA
RAILING
PASSION



Pasión por el diseño

VARIETAD EN HERRAJES

Comenza es la compañía global de sistemas de barandillas de diseño que proporciona soluciones creativas a las necesidades de las personas en los espacios que habitan, a través de productos de alta calidad que garanticen su seguridad y bienestar.

Durante estos últimos años nos hemos convertido en una de las referencias a nivel mundial en diseño y desarrollo de sistemas de barandillas modulares para proyectos hoteleros, edificios residenciales y comerciales, centros comerciales, sedes de empresa e institucionales, viviendas unifamiliares etc.

Esto ha sido posible gracias a una decidida apuesta por nuestro departamento de I+D+I que nos permite lanzar al mercado sistemas de barandillas únicos en diseño y prestaciones.

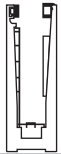

Sistema / System / Système
GlassFit SV-1301
Top

1380250012NA

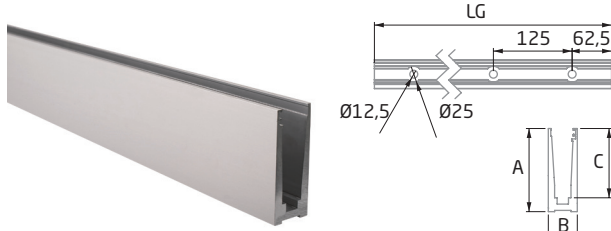

SV-1301-1

	LG	A	B	C
1	2500	132	46	110



PL-11

G	/A	/B	D (LG)	E (LG)
12-12,38	10	10	2500	2500
15	10	10	2500	2500

El vidrio no necesita ser taladrado. Sistema de fijación con cuñas.
 No need to drill glass panels. Fixing Wedge System.
 Le verre n'a pas besoin d'être percé. Système de fixation avec des cales.



1380250012NA

RIEL DE BARANDAL PARA VIDRIO DE 12MM.
 NATURAL ANODIZADO

138003800

JUEGO DE CALZOS, EMPAQUES DE EPDM Y GOMAS PARA
 VIDRIO DE 12MM.

Posibilidades de anclaje SV-1301 / Anchoring possibilities for the SV-1301 / Possibilités d'ancrage SV-1301

1 FIS VS 300T M-10	2 FH II S M-10
C25/30 Uncracked	C25/30 Cracked / Uncracked
FIS VS 300 T M10 + DIN 975 + DIN 934 + DIN 125	FH II S M-8 L-105 \varnothing 12
FIS VS 300 T + RG MI M10 L90 + DIN 933 + DIN 125	FIS SB 390 S M10 + DIN 975 + DIN 934 + DIN 125
	FIS SB 390 S + RG MI M10 L90 + DIN 933 + DIN 125

* Consultar idoneidad de usos según parámetros de instalación.
 Consult adequacy of uses according to installation parameters.
 Vérifier la pertinence de l'utilisations par rapport au paramètres d'installation.

* Cracked / Uncracked
 Hormigón Traccionado / Hormigón Comprimido
 Béton comprimé / Béton en traction

* Calidad recomendada de hormigón comprimido y traccionado C25/30.
 Recommended quality for uncracked/cracked concrete C25/30.
 Qualité recommandé du béton comprimé et en traction C25/30.

New!



BR-2041



1



BR-2039



1

138010700

HERRAMIENTA PARA COLOCACIÓN DE CALZOS.

138010600

HERRAMIENTA PARA COLOCACIÓN DE EMPAQUES DE EPDM.

VARIEDAD EN HERRAJES

TOLUCA

Instalación / Installation / Installation

BR-2039 / BR-2041

1 BR-2041: Fijación / Fixation / Fixation

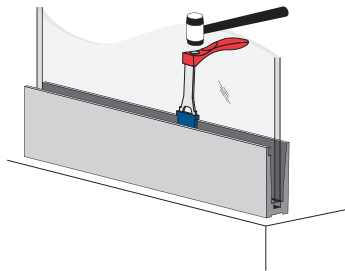

2 BR-2041: Extracción / Removal / Enlèvement

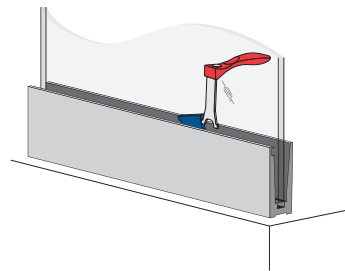

3 BR-2039

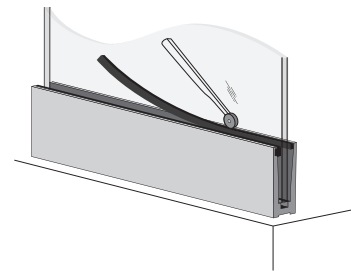

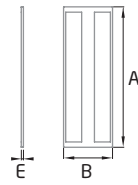

PM-24

	A	B	E
1	132	46	2

*Included

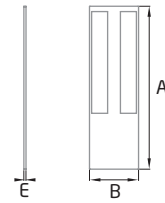

PM-25

	A	B	E
1	206	46	2

*Included

1380039NA
TAPA LATERAL PARA SV-1301.
NATURAL ANODIZADO

1380040NA
TAPA LATERAL PARA SV-1301.
NATURAL ANODIZADO

VARIEDAD EN HERRAJES

TOLUCA

Instalación / Installation / Installation

PM-25

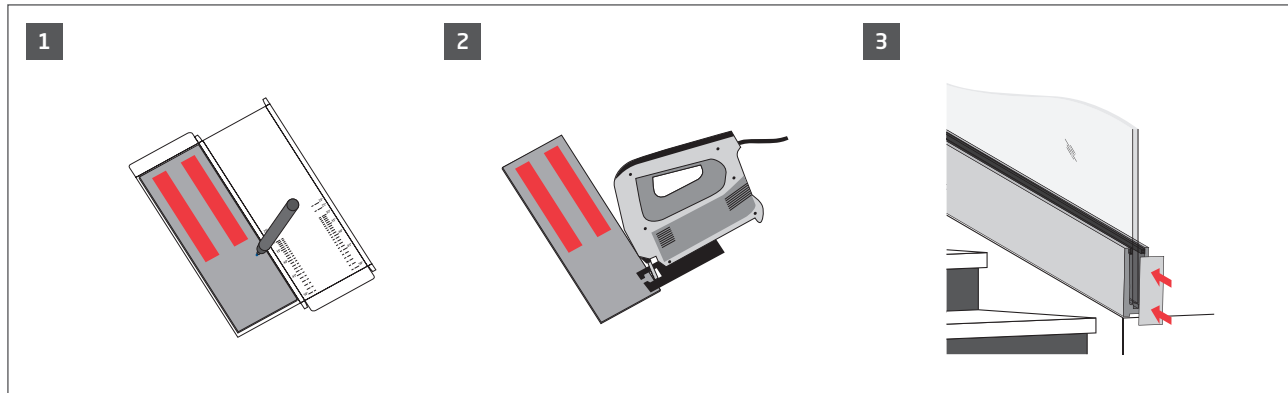

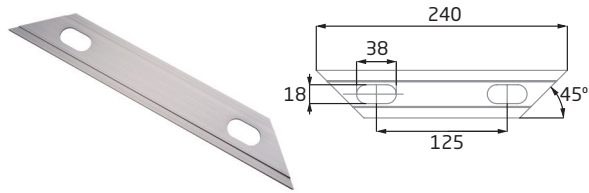

PM-26



10

Perfil de drenaje.
Profile for drainage.
Profil de drainage.

1380041NA

CALZA PARA DRENAJE SV-1301.
NATURAL ANODIZADO

Sistema de drenaje / Drainage system / Système de drainage

PM-26

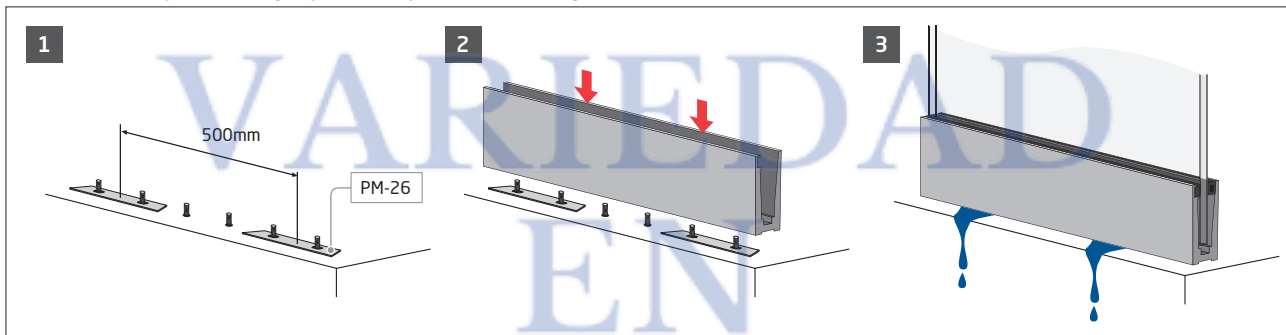

Instalación / Installation / Installation

SV-1301

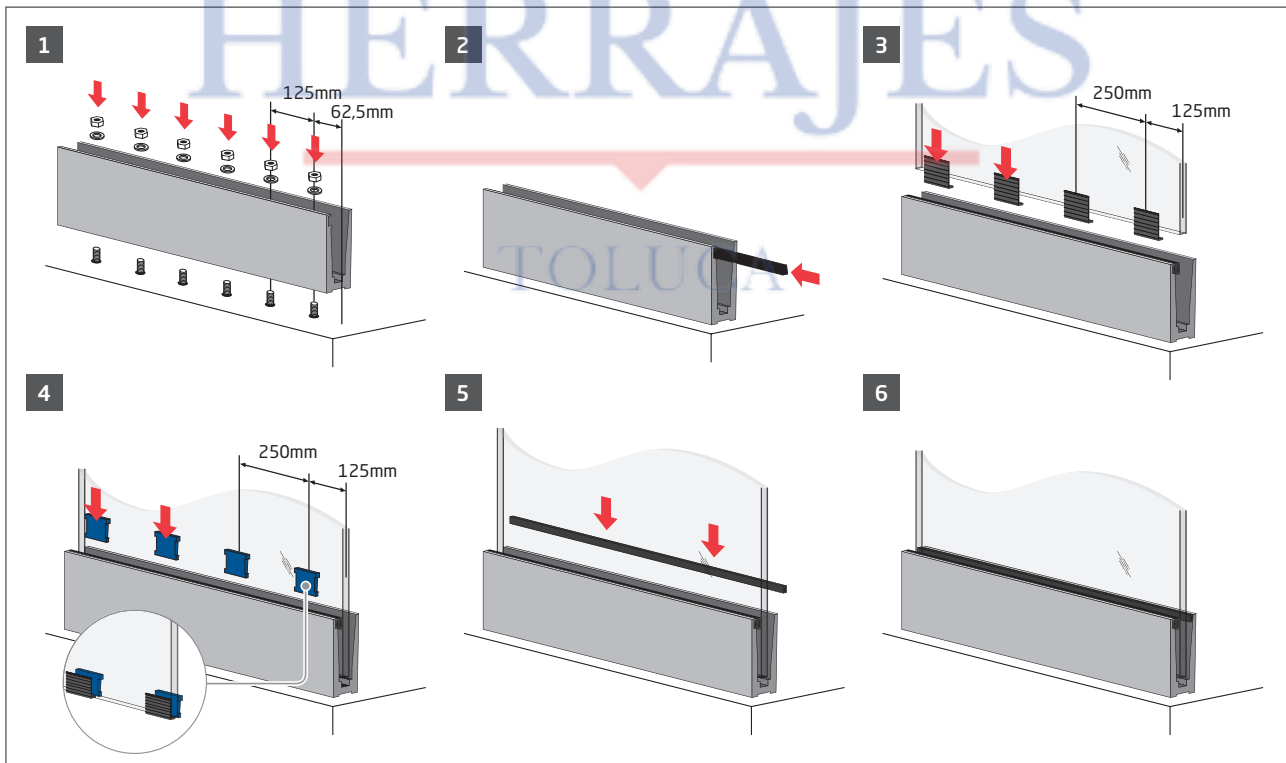

Ver video de instalación en / Watch installation video at / Voir video d'installation à www.comenza.com



Pasión por la seguridad



Descargar / Download / Télécharger
www.comenza.com

Visita nuestra web en www.comenza.com para descargar los ensayos de cargas certificados por Applus y CSTB y demuestra a tus clientes por que la pasión por la seguridad de Comenza es más que un compromiso. Y recuerda que estos certificados son imprescindibles para garantizar el cumplimiento de la normativa de barandillas.

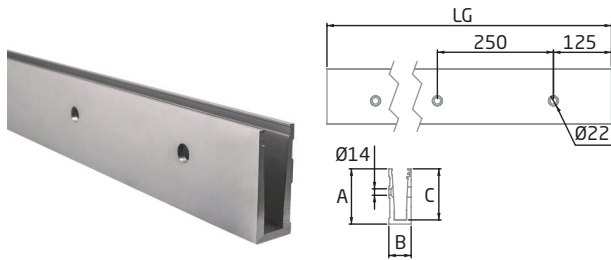

SV-1302-2

	LG	A	B	C
1	2500	119	49	110

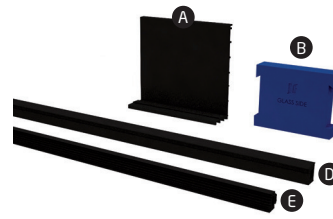

PL-11

G	/A	/B	D (LG)	E (LG)
12-12.38	10	10	2500	2500
15	10	10	2500	2500

El vidrio no necesita ser taladrado. Sistema de fijación con cuñas.
 No need to drill glass panels. Fixing Wedge System.
 Le verre n'a pas besoin d'être percé. Système de fixation avec des cales.



1380059250NA

RIEL DE BARANDAL PARA VIDRIO DE 12MM
 INSTALACIÓN LATERAL.
 NATURAL ANODIZADO

138003800

JUEGO DE CALZOS, EMPAQUES DE EPDM Y GOMAS PARA
 VIDRIO DE 12MM.

VARIEDAD EN HERRAJES

Posibilidades de anclaje SV-1302 / Anchoring possibilities for the SV-1302 / Possibilités d'ancrage SV-1302

1 FH II SK M-8 L-100 Ø 12

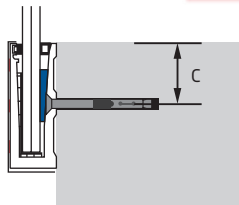

Uncracked: C = 60 mm
 Cracked: C = 50 mm

C25/30 Uncracked	C25/30 Cracked / Uncracked
FH II SK M-8 L-100 Ø 12	FH II SK M-8 L-100 Ø 12
FIS VS 300 T + RG MI M10 L90 + DIN 933 + DIN 125	FIS SB 390 S + RG MI M10 L90 + DIN-7991 M-10 L-20

- * Consultar idoneidad de usos según parámetros de instalación.
 Consult adequacy of uses according to installation parameters.
 Vérifier la pertinence de l'utilisations par rapport au paramètres d'installation.
- * Cracked / Uncracked
 Hormigón Traccionado / Hormigón Comprimido
 Béton comprimé / Béton en traction
- * Calidad recomendada de hormigón comprimido y traccionado C25/30.
 Recommended quality for uncracked/cracked concrete C25/30.
 Qualité recommandé du béton comprimé et en traction C25/30.



New!



BR-2041



1



BR-2039



1

138010700

HERRAMIENTA PARA COLOCACIÓN DE CALZOS.

138010600

HERRAMIENTA PARA COLOCACIÓN DE EMPAQUES DE EPDM.

VARIEDAD EN HERRAJES

TOLUCA

Instalación / Installation / Installation

BR-2039 / BR-2041

1 BR-2041: Fijación / Fixation / Fixation

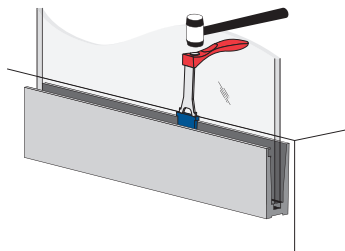

2 BR-2041: Extracción / Removal / Enlèvement

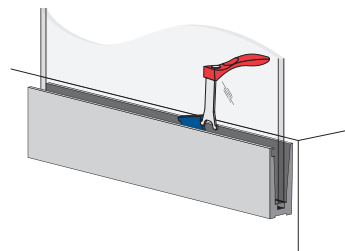

3 BR-2039

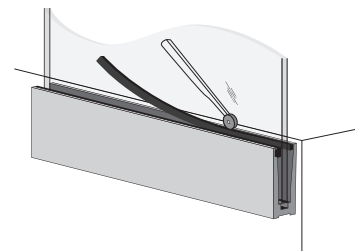

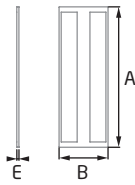

PM-29

	A	B	E
1	124	51	2

Para tramos rectos.
For straight sections.
Pour des sections horizontal.



*Included

QLTY: Aluminium

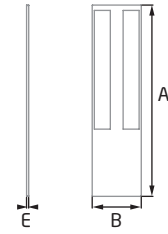

PM-30

	A	B	E
1	196	51	2

Para tramos en ángulo.
For sloping sections.
Pour des sections inclinés.



*Included

QLTY: Aluminium

1380057NA

TAPA LATERAL PARA SV-1302.
NATURAL ANODIZADO

1380058NA

TAPA LATERAL PARA SV-1302.
NATURAL ANODIZADO

VARIEDAD EN HERRAJES

TOLUCA

Instalación / Installation / Installation

PM-30

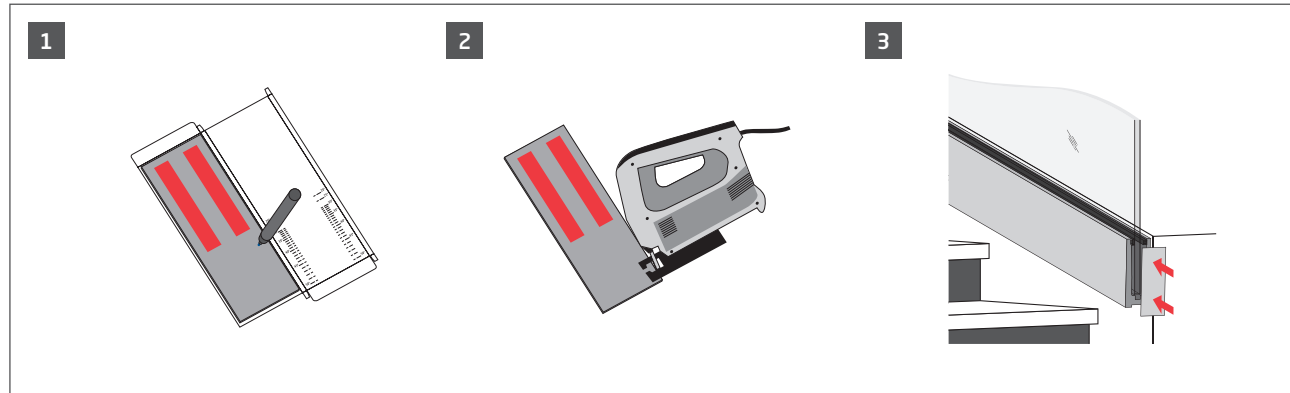



PM-52

LG	A	B	E
2500	124	48	1



*Not Included

QLTY: Aluminium

1380060250NA

TAPA FRONTAL PARA SV-1302.
NATURAL ANODIZADO

VARIEDAD EN HERRAJES

Instalación / Installation / Installation

GlassFit SV-1302

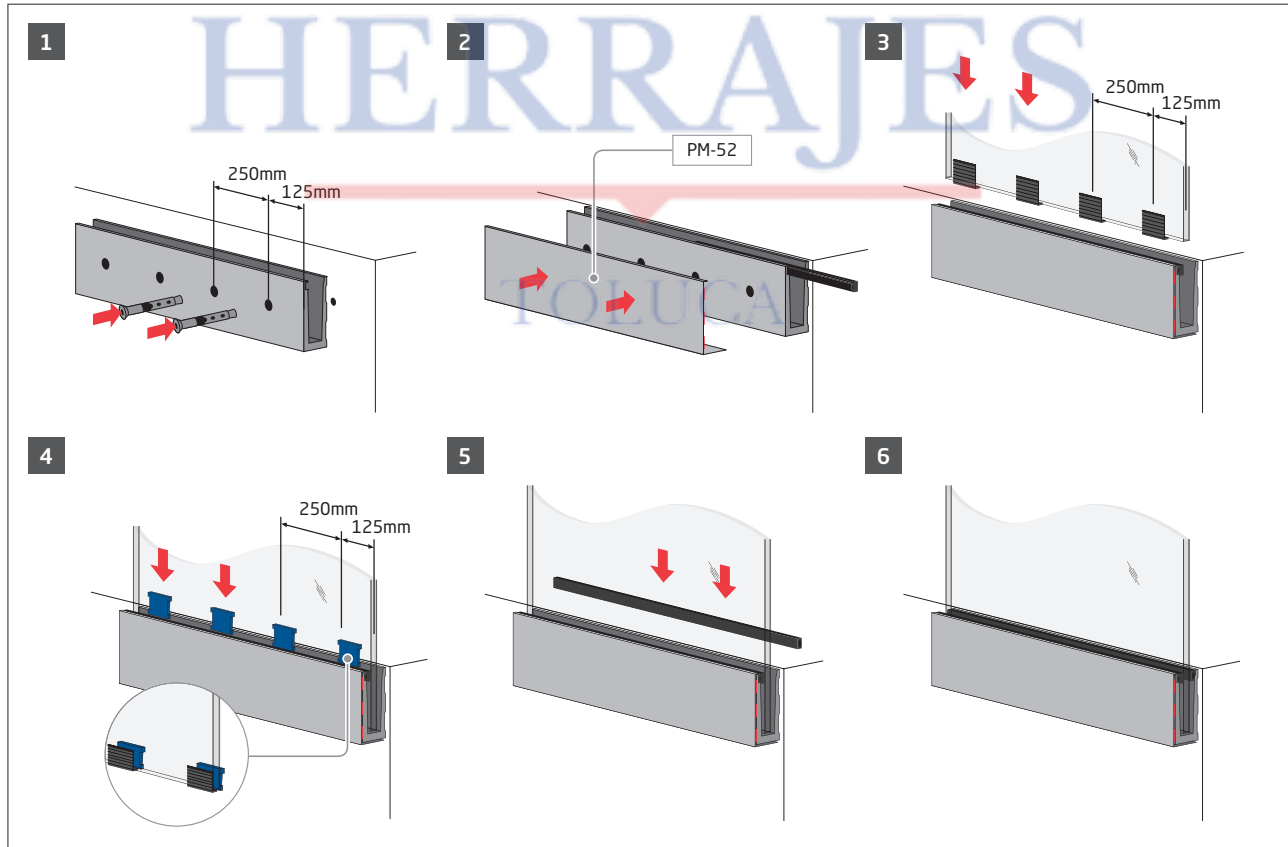



Sistema / System / Système
GlassFit CC-780

1380022SA

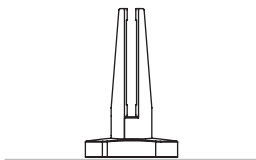

Sistema / System / Système
GlassFit CC-781

1380042SA



New!

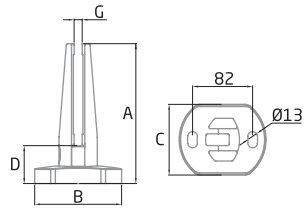

CC-781 AISI-304

SATIN

	A	B	C	D	G
1	190	118	96	52	9.52-12.70

BR-2031

	Ø
1	11 a 60

No regulable.
Non adjustable.
Non ajustable.



1380042SA

PINZA PARA VIDRIO A SUELO DE ACERO INOXIDABLE 304 SIN BARRENOS PARA VIDRIO DE 10 A 12MM. SATINADO

138010500

PINZA PARA INSTALACIÓN DE HERRAJE CC-780 Y CC-781.

Posibilidades de anclaje CC-781 / Anchoring possibilities for the CC-781 / Possibilités d'ancrage CC-781

C25/30 Uncracked	C25/30 Cracked / Uncracked
FBN II M12 L-116	FAZ II M-12 L-120
FIS VS 300 T M-12 + DIN 975+ DIN-934 + DIN 125	FIS SB 390 S M12 + DIN 975 + DIN 934 + DIN 125

* Cracked / Uncracked
Hormigón Traccionado / Hormigón Comprimido
Béton comprimé / Béton en traction

Instalación / Installation / Installation

CC-781

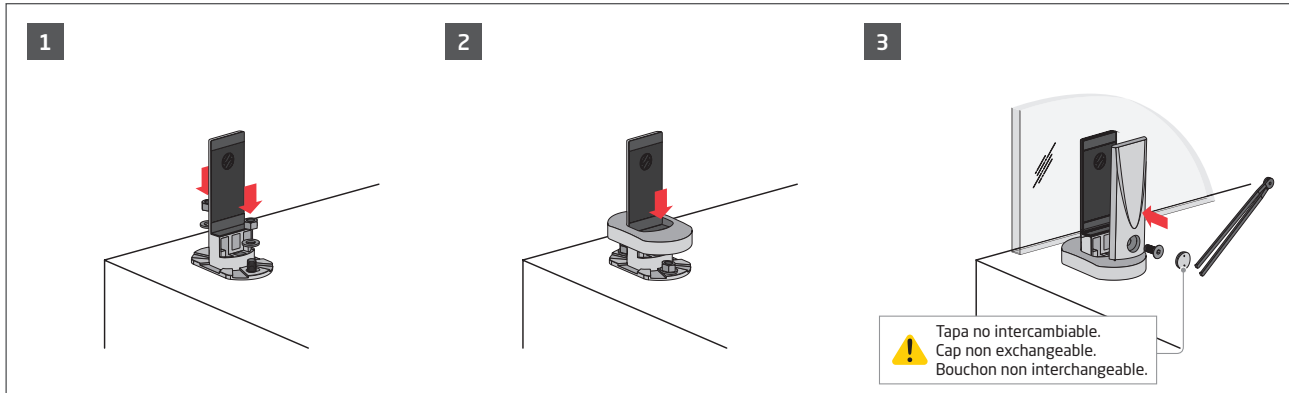



 **comenza**
Railing Passion

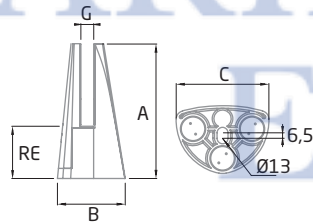

CC-780 AISI-304

	A	B	C	RE	G
1	160	80	110	60-65	12-17.52

SATIN

BR-2031

	Ø
1	11 a 60

Regulable.
Adjustable.
Ajustable.



1380022SA

ABA CONECTOR BASE PARA BARANDAL DE 12-17.52MM.
SATINADO

138010500

PINZA PARA INSTALACIÓN DE HERRAJE CC-780 Y CC-781.

Posibilidades de anclaje CC-780 / Anchoring possibilities for the CC-780 / Possibilités d'ancrage CC-780

C25/30 Uncracked	C25/30 Cracked / Uncracked
FIS VS 300 T M-12 + DIN 975+ DIN-934 + DIN 125	FIS SB 390 S M-12 + DIN 975+ DIN-934 + DIN 125

* Consultar idoneidad de usos según parámetros de instalación.
Consult adequacy of uses according to installation parameters.
Vérifier la pertinence de l'utilisations par rapport au paramètres d'installation.

* Cracked / Uncracked
Hormigón Traccionado / Hormigón Comprimido
Béton comprimé / Béton en traction

* Calidad recomendada de hormigón comprimido y traccionado C25/30.
Recommended quality for uncracked/cracked concrete C25/30.
Qualité recommandé du béton comprimé et en traction C25/30.



Instalación / Installation / Installation

CC-780

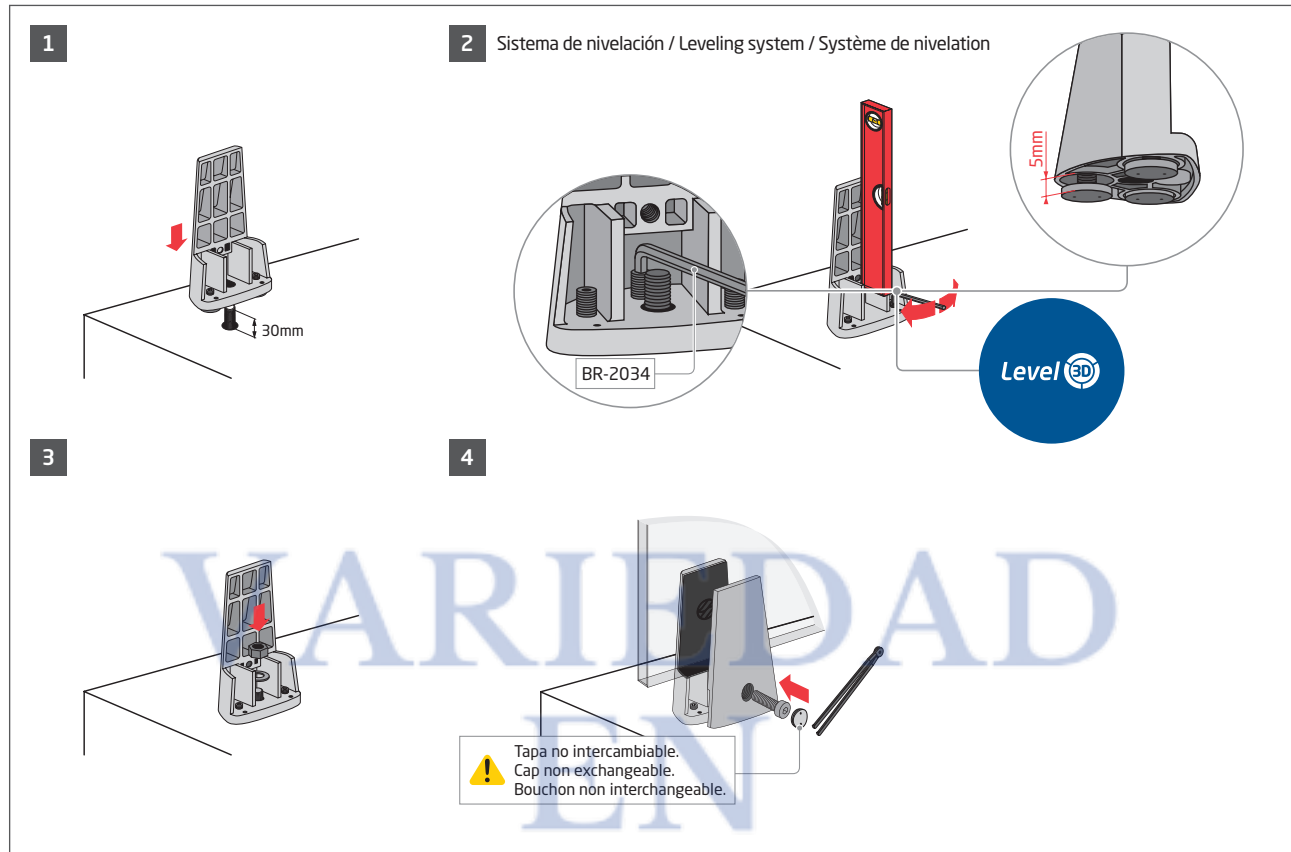

* Sistema nivelador de tres puntos (regula los ejes XYZ) / Three point leveling system (adjust axis XYZ) / Système niveleur trois points (règle les axes XYZ)

VARIETAD
EN
HERRAJES
TOLUCA

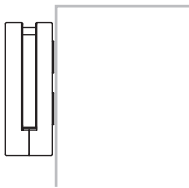

Sistema / System / Système
GlassFit CC-791

1380043SA

New!

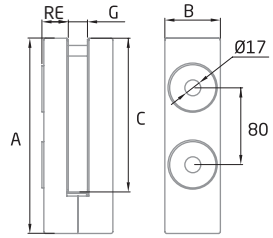

CC-791 AISI-304 SATIN					
	A	B	C	RE	G
1	203	58	160	27-33	16.38-21.52

Regulable.
Adjustable.
Ajustable.



1380043SA
PINZA LATERAL DE ACERO INOXIDABLE 304 SIN BARRENOS
PARA VIDRIO DE 16.38 A 21.5MM.
SATINADO

Posibilidades de anclaje CC-791 / Anchoring possibilities for the CC-791 / Possibilités d'ancrage CC-791

C25/30 Uncracked	C25/30 Cracked / Uncracked
FIS VS 300 T M-12 + DIN-975 + DIN 934 + DIN 125	FIS SB 390 S M12 + DIN 975 + DIN 934 + DIN 125

* Cracked / Uncracked
Hormigón Traccionado / Hormigón Comprimido
Béton comprimé / Béton en traction

Instalación / Installation / Installation

CC-791



1 Dispositivo interior que permite ajustes de 360°
Inner device that allows 360° adjustments
Dispositif intérieur permettant des réglages de 360°

2 Sistema de nivelación / Leveling system / Système de nivelation

3

4

5

  Ver video de instalación en / Watch installation video at / Voir video d'installation à www.comenza.com

Instalación vidrio con taladros / Glass installation with drilling / Installation du verre avec perçage

CC-791

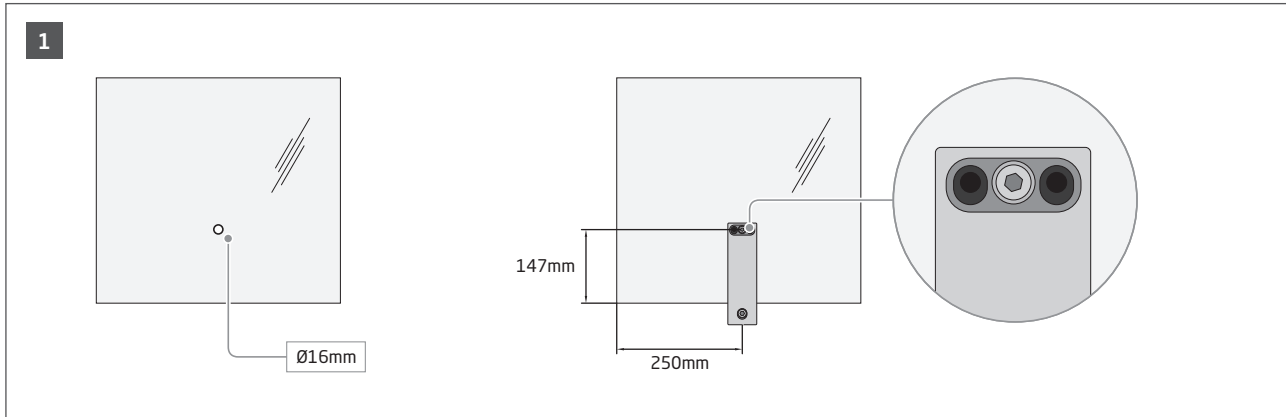

Instalación vidrio sin taladros / Glass installation without drilling / Installation du verre sans perçage

CC-791

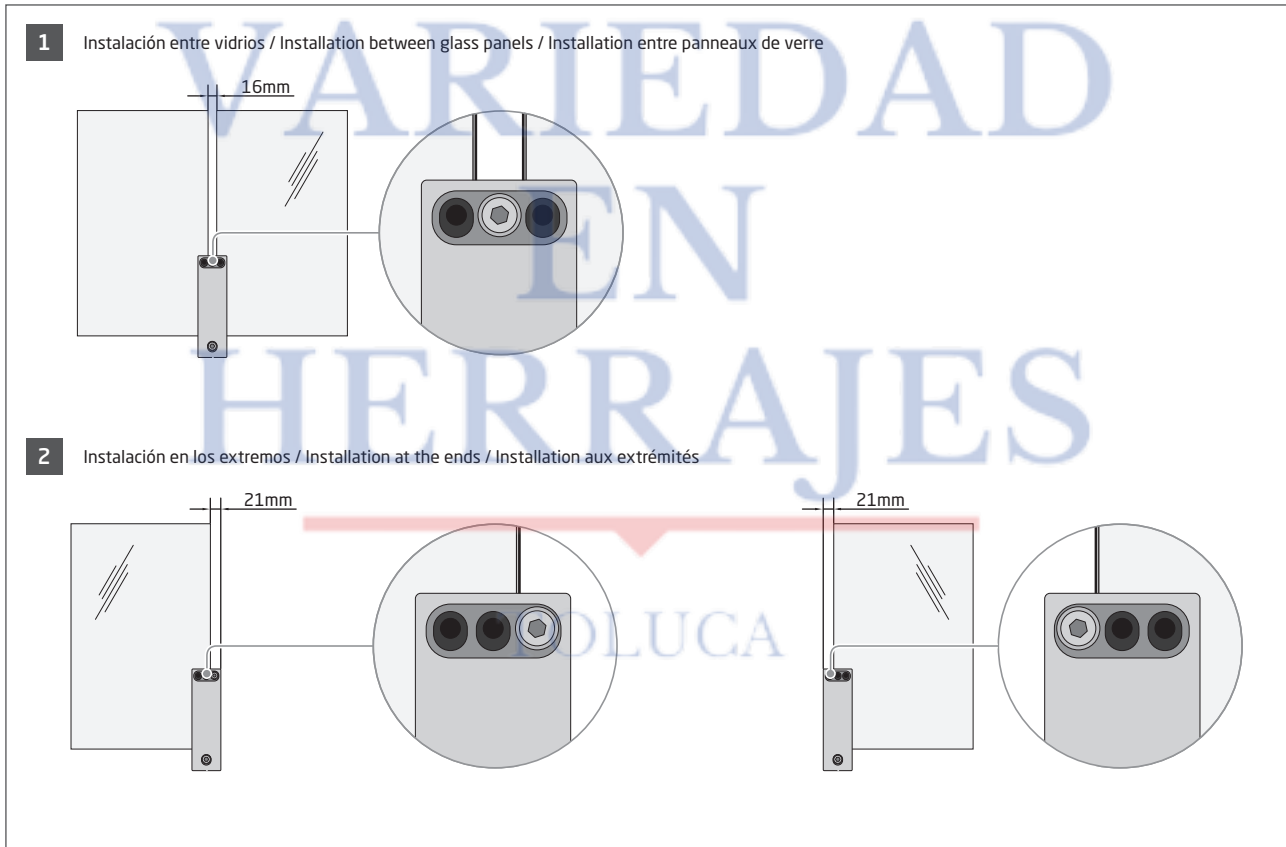



Videos de instalación



Visita nuestra página web en www.comenza.com y te demostraremos por que nuestros sistemas de barandillas no sólo son los más seguros del mundo sino también los más fáciles de instalar.

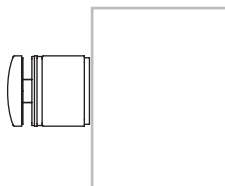

Sistema / System / Système
GlassFit CC-772

1380044SA

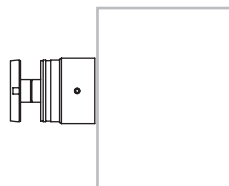

Sistema / System / Système
GlassFit CC-775

1380045030SA



New!

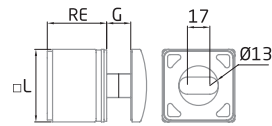

CC-772 AISI-304

SATIN

	L	RE	G
2	55	45-50	8-21.52

Regulable.
Adjustable.
Ajustable.



1380044SA

CONECTOR CUADRADO LATERAL DE ACERO INOXIDABLE 304 PARA VIDRIO DE 8 A 21.5MM. SATINADO

Posibilidades de anclaje CC-772 / Anchoring possibilities for the CC-772 / Possibilités d'anclage CC-772

C25/30 Uncracked	C25/30 Cracked / Uncracked
FBN II M-12 L-116	FAZ II M-12 L-120
FIS VS 300 T M-10 + DIN-975 + DIN 934 + DIN 125	FIS SB 390 S M10 + DIN 975 + DIN 934 + DIN 125
FIS VS 300 T + RG MI M10 L90 + DIN 933 + DIN 125	FIS SB 390 S + RG MI M10 L90 + DIN 933 + DIN 125

* Cracked / Uncracked
Hormigón Traccionado / Hormigón Comprimido
Béton comprimé / Béton en traction

Sistema de regulación CC-772 / CC-772 adjustment system / Système de réglage CC-772

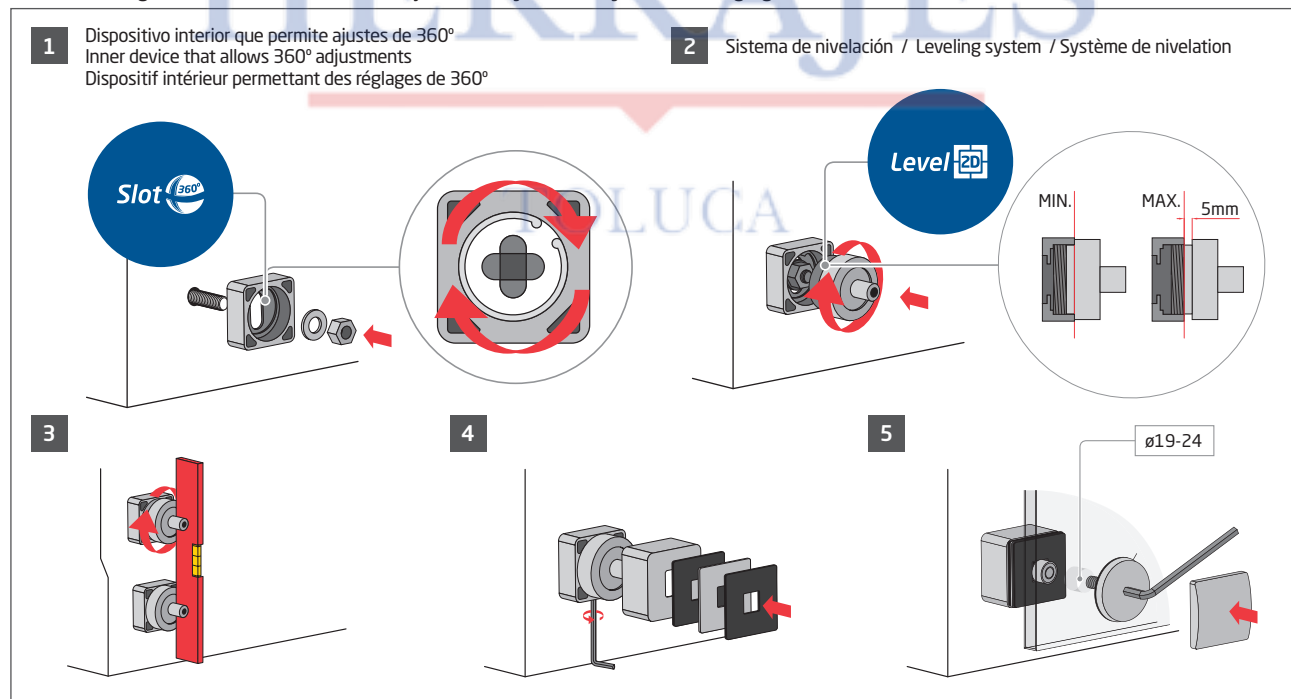

Ver video de instalación en / Watch installation video at / Voir video d'installation à www.comenza.com

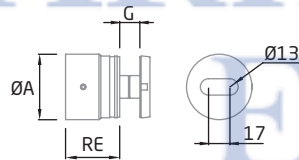

CC-775 D.50 AISI-304

	Ø	RE	G	
2	52	45-50	8-21.52	SATIN

BR-2030

	Ø
1	45-50

Regulable.
Adjustable.
Ajustable.



1380017SA

CONECTOR REDONDO LATERAL DE 50MM DE DIÁMETRO EN ACERO INOXIDABLE 304 PARA VIDRIO DE 8 A 21.5MM. SATINADO

138010400

HERRAMIENTA DE FIJACIÓN PARA DIÁMETRO DE 50MM (CC775).

Posibilidades de anclaje CC-775 D.50 / Anchoring possibilities for the CC-775 D.50 / Possibilités d'ancrage CC-775 D.50

C25/30 Uncracked	C25/30 Cracked / Uncracked
FBN II M-12 L-116	FAZ II M-12 L-120
FIS VS 300 T M-10 + DIN-975 + DIN 934 + DIN 125	FIS SB 390 S M10 + DIN 975 + DIN 934 + DIN 125
FIS VS 300 T + RG MI M10 L90 + DIN 933 + DIN 125	FIS SB 390 S + RG MI M10 L90 + DIN 933 + DIN 125

* Cracked / Uncracked
Hormigón Traccionado / Hormigón Comprimido
Béton comprimé / Béton en traction



New!

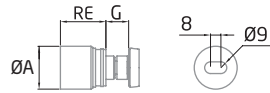

CC-775 D.30 AISI-304

SATIN

	ØA	RE	G
2	33	35-40	8-17.52

Regulable.
Adjustable.
Ajustable.



1380045030SA

CONECTOR REDONDO LATERAL DE 30MM DE DIÁMETRO EN ACERO INOXIDABLE 304 PARA VIDRIO DE 8 A 21.5MM. SATINADO

Posibilidades de anclaje CC-775 D.30 / Anchoring possibilities for the CC-775 D.30 / Possibilités d'ancrage CC-775 D.30

C25/30 Uncracked	C25/30 Cracked / Uncracked
FIS VS 300 T M-8 + DIN-975 + DIN 934 + DIN 125	FIS SB 390 S M-8 + DIN-975 + DIN 934 + DIN 125

* Cracked / Uncracked
Hormigón Traccionado / Hormigón Comprimido
Béton comprimé / Béton en traction

Sistema de regulación CC-775 / Sistema de regulación CC-775 / Système de régulation CC-775

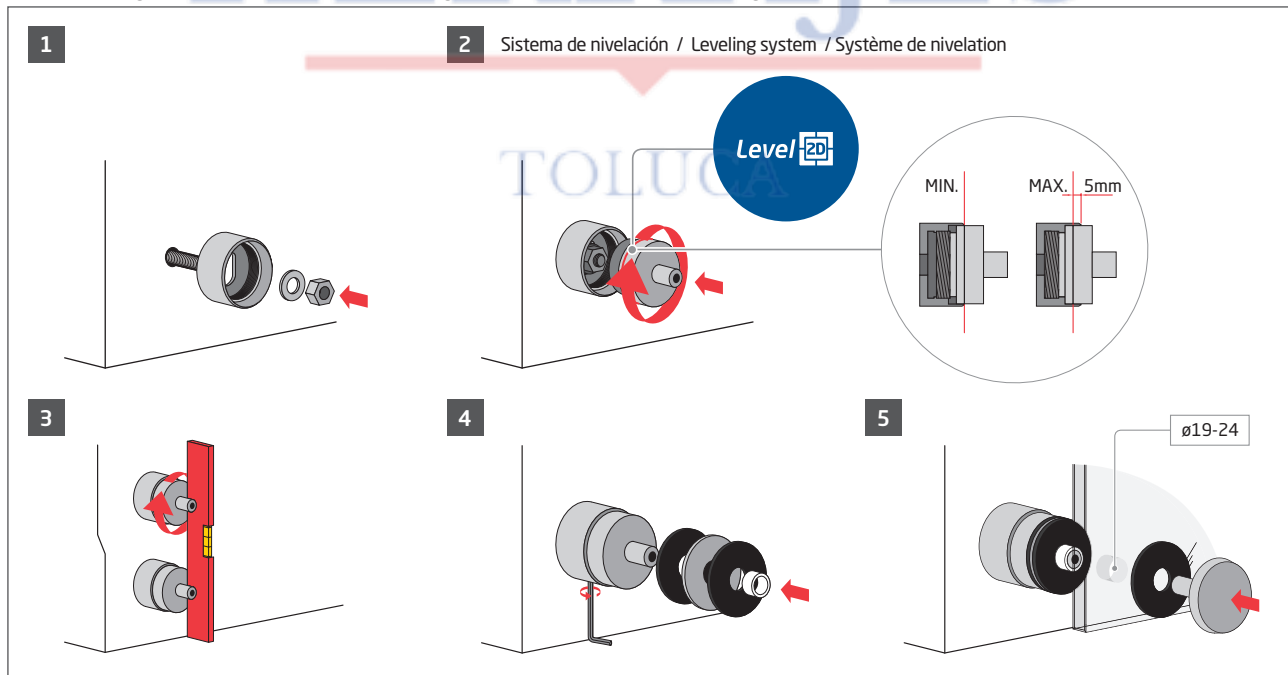

Ver video de instalación en / Watch installation video at / Voir video d'installation à www.comenza.com

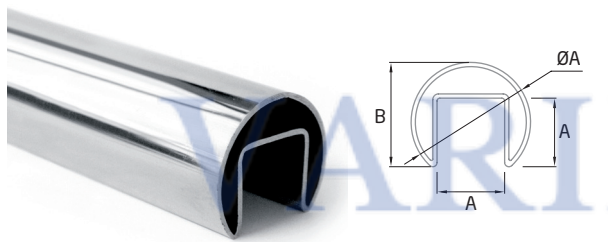
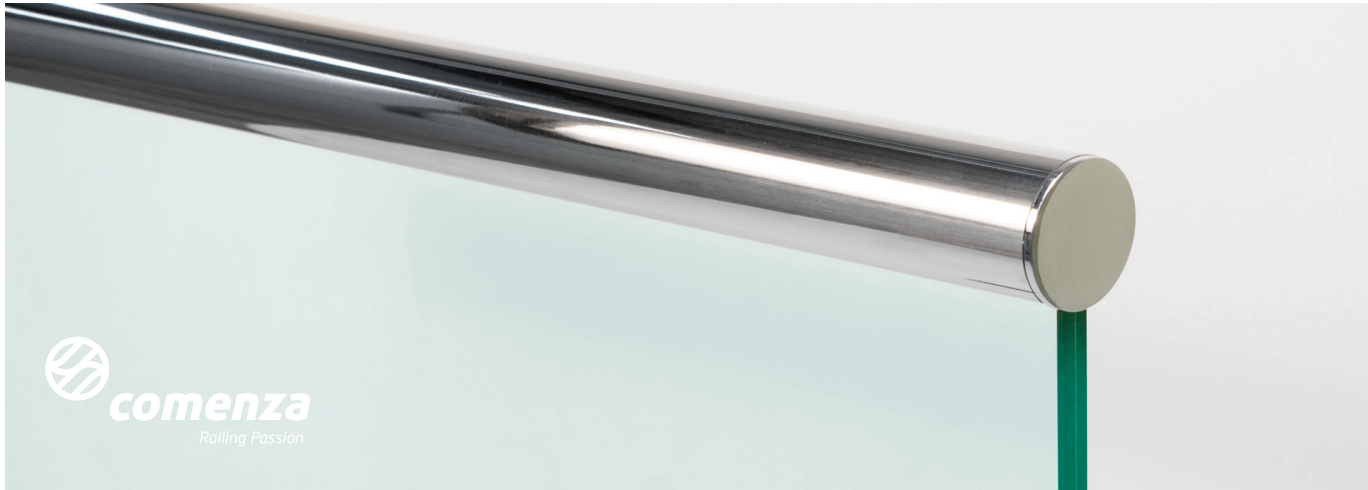

RP-1400 AISI-304 SATIN

LG	øA	A	B	E*
5000	42.4	24	37	1.5



PL-03

LG	A	G
5000	24	8-11.52
5000	24	12-13.52
5000	24	15

1380047500SA
 TUBO EN "U" DE ACERO INOXIDABLE 304
 PARA BARANDAL DE VIDRIO.
 SATINADO

1380048500NE
 EMPAQUE DE EPDM PARA VIDRIO.
 NEGRO

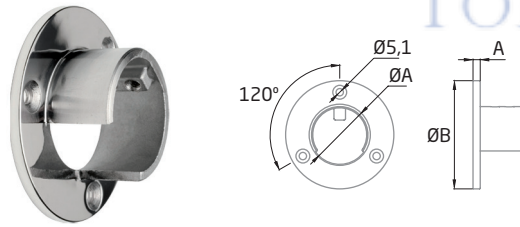

AV-609 AISI-304 SATIN

2	øA	øB	A	E*
2	42.4	75	5	1.5



1380049SA
 CONECTOR LATERAL DE ACERO INOXIDABLE 304.
 SATINADO



TF-512 AISI-304 SATIN

2	øA	A	E*
2	42.4	3	1.5



1380050SA
 TAPA LATERAL DE ACERO INOXIDABLE 304.
 SATINADO



CT-211 AISI-304

SATIN

	$\varnothing A$	A	E*
2	42.4	50	1.5

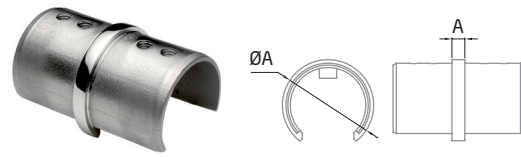

CT-212 AISI-304

SATIN

	$\varnothing A$	A	E*
2	42.4	4	1.5



1380051SA

CODO A 90° DE ACERO INOXIDABLE 304.
SATINADO

1380052SA

CONECTOR DE ACERO INOXIDABLE 304.
SATINADO

VARIEDAD
EN
HERRAJES

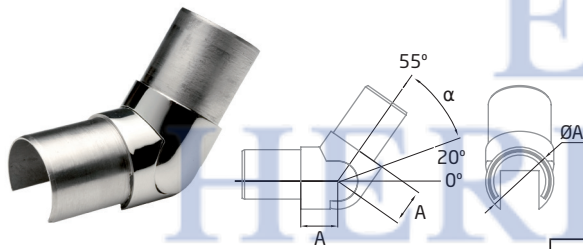

SA-416 AISI-304

SATIN

	$\varnothing A$	A	E*	α
2	42.4	23	1.5	20-25°

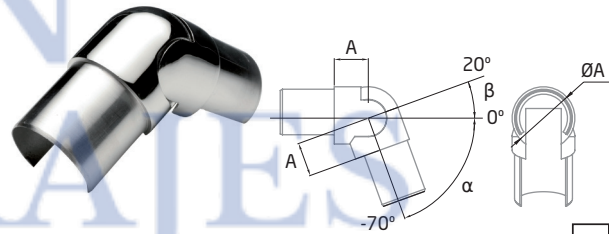

SA-417 AISI-304

SATIN

	$\varnothing A$	A	E*	α	β
2	42.4	23	1.5	0-70°	0-20°



1380053SA

CODO AJUSTABLE EN ACERO INOXIDABLE 304.
SATINADO

1380054SA

CODO AJUSTABLE EN ACERO INOXIDABLE 304.
SATINADO

TOLUCA

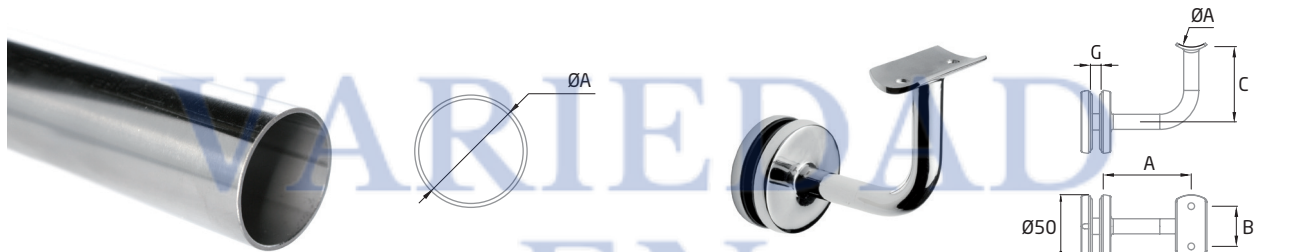

CLAVE	E	ØA	LG
2251018012SA	CAL. 18	1/2"	6.10MTS
2251018112SA	CAL. 18	1 1/2"	6.10MTS
2251018200SA	CAL. 18	2"	6.10MTS

TUBO DE ACERO INOXIDABLE.
SATINADO

CLAVE	ØA	A	B	C	G
2	50.8	70	32	59.5	(6-21.52)



1380016200SA
SOPORTE LATERAL 50.8MM DE ACERO INOXIDABLE 304.
SATINADO

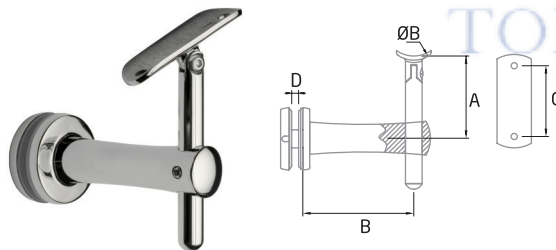

CLAVE	ØB	A	B	C	D
2	50.8	30-70	80	61.5	6-17.52



1380028200SA
SOPORTE AJUSTABLE 50.8MM DE ACERO INOXIDABLE 304.
SATINADO

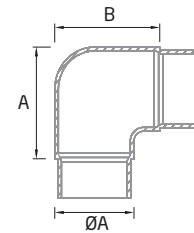

CLAVE	ØA	A	B	E*
1380003112SA	2	38.1	55	1.5
1380003200SA	2	50.8	60	1.5

CODO RECTO DE ACERO INOXIDABLE A 90°.
SATINADO

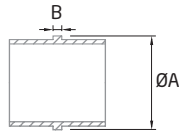

CT-207 AISI-304

CLAVE		ØA	B	E*
1380006112SA	2	38.1	4	1.5
1380006200SA	2	50.8	4	1.5

UNIÓN DE ACERO INOXIDABLE PARA TUBO.
SATINADO

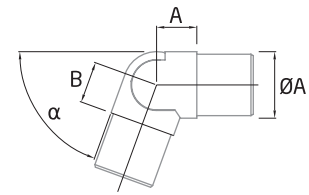

SA-406 AISI-304

CLAVE		ØA	A	B	E*	α
1380007012SA	4	12.7	8	8	1	0-70°
1380007112SA	2	38.1	23	23	1.5	0-70°
1380007200SA	2	50.8	32	32	1.5	0-70°

CODO AJUSTABLE DE ACERO INOXIDABLE CONECTOR-TUBO.
SATINADO

*Este producto será sustituido por la clave **SA-409** con regulación angular de 0-90° (Pag. 46).

VARIEDAD
EN
HERRAJES

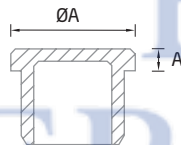

TF-502 AISI-304

CLAVE		ØA	A	E*
1380009012SA	2	12.7	2	1
1380009112SA	2	38.1	2	1.5
1380009200SA	2	50.8	2	1.5

TAPA PLANA DE ACERO INOXIDABLE PARA TUBO.
SATINADO

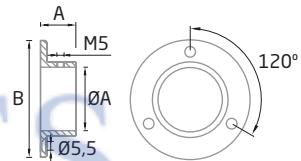

AV-601 AISI-304

	ØA	A	B
2	50.8	31	102

BR-2087 Ø4,5-6,0



1380001200SA

BASE SIN TAPA ACERO INOXIDABLE PARA PARED (LATERAL).
SATINADO

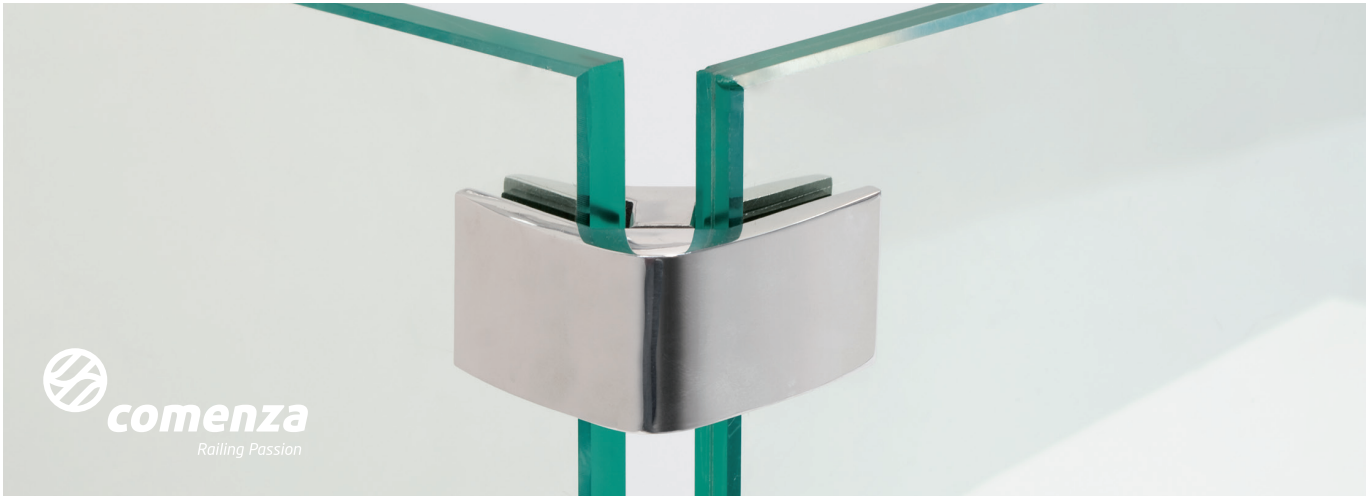

New!

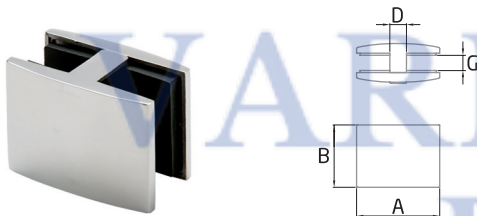

CC-736 AISI-304

	A	B	D	G
	60	45	12	(8-13.52)

SATIN

New!



CC-737 AISI-304

	A	B	D	G
	60	35	14	(8-13.52)

SATIN



1380055A

CONECTOR VIDRIO A VIDRIO EN ACERO INOXIDABLE 304
PARA VIDRIO DE 8 A 13.5MM.
SATINADO



1380056SA

CONECTOR VIDRIO A VIDRIO A 90° EN ACERO INOXIDABLE
304 PARA VIDRIO DE 8 A 13.5MM.
SATINADO

TOLUCA

Instalación / Installation / Installation

CC-736

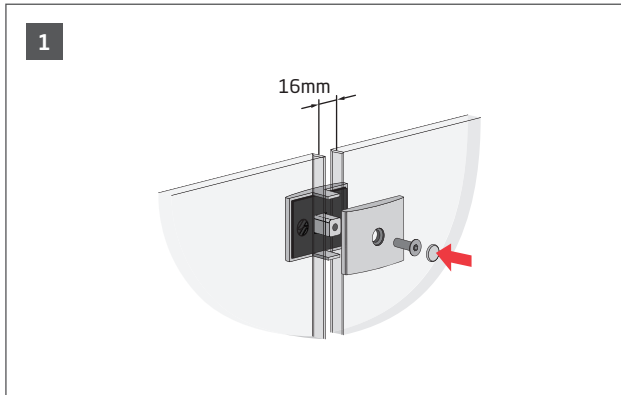

Instalación / Installation / Installation

CC-737

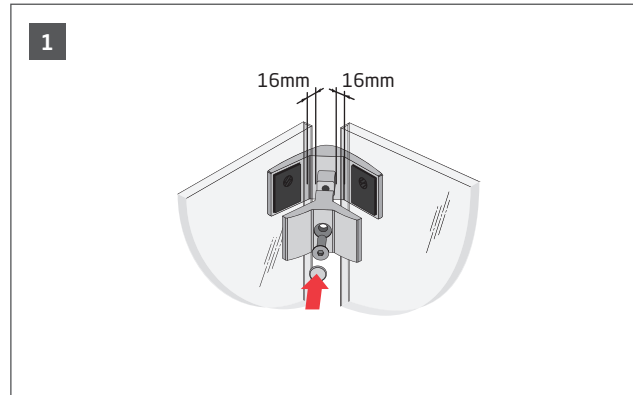



Pasión por el diseño



TOLUCA



Diseño exclusivo, seguridad y facilidad de instalación.

En Comenza estamos convencidos de que esas son las razones por las cuales los arquitectos más relevantes del panorama internacional nos consideran la marca preferida en sistemas de barandillas

Visita nuestra galería de proyectos en www.comenza.com y déjate inspirar con alguno de los proyectos en donde nuestros sistemas de barandillas han sido instalados.

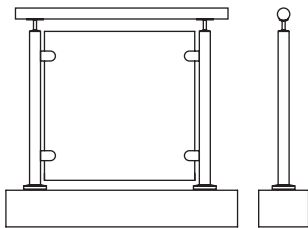

Sistema / System / Système
R-Concept: Glass

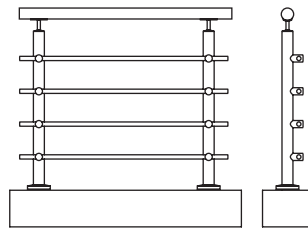

Sistema / System / Système
R-Concept: Tube

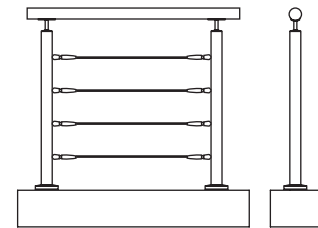

Sistema / System / Système
R-Concept: EasyCable

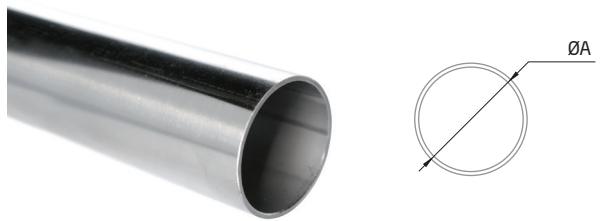

CLAVE	E	ØA	LG
2251018012SA	CAL. 18	1/2"	6.10MTS
2251018112SA	CAL. 18	1 1/2"	6.10MTS
2251018200SA	CAL. 18	2"	6.10MTS

TUBO DE ACERO INOXIDABLE.
SATINADO

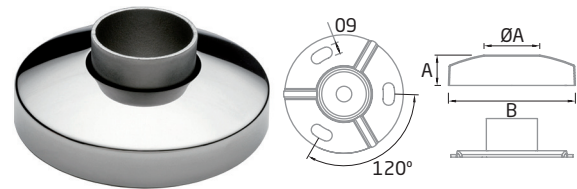

CLAVE	ØA	A	B	E*
1380002112SA	2	38.1	22.5	99
1380002200SA	2	50.8	22.5	99

BASE CON TAPA DE ACERO INOXIDABLE PARA PISO.
SATINADO

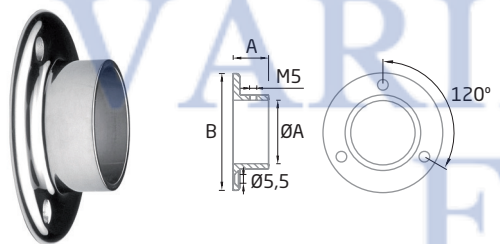

CLAVE	ØA	A	B
2	50.8	31	102

BR-2087 (Brico Pag. 68)

1380001200SA
BASE SIN TAPA ACERO INOXIDABLE PARA PARED (LATERAL).
SATINADO

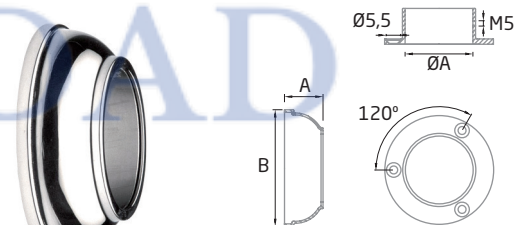

CLAVE	ØA	A	B
1380035112SA	2	38.1	25
1380035200SA	2	50.8	29

BR-2087

BASE CON TAPA ACERO INOXIDABLE.
SATINADO

TOLUCA

Posibilidades de anclaje BS-00 / Anchoring possibilities for the BS-00 / Possibilités d'ancrage BS-00

	C25/30 Uncracked	C25/30 Cracked / Uncracked
	FIS VS 300 T M-8 + DIN 975 + DIN 934 + DIN 125	FIS SB 390 S M-8 + DIN 975 + DIN 934 + DIN 125
	FIS VS 300 T M-12 + DIN 975 + DIN 934 + DIN 125	FIS SB 390 S M-12 + DIN 975 + DIN 934 + DIN 125

* Consultar idoneidad de usos según parámetros de instalación.
Consult adequacy of uses according to installation parameters.
Vérifier la pertinence de l'utilisations par rapport au paramètres d'installation.

* Cracked / Uncracked
Hormigón Traccionado / Hormigón Comprimido
Béton comprimé / Béton en traction

* Calidad recomendada de hormigón comprimido y traccionado C25/30.
Recommended quality for uncracked/cracked concrete C25/30.
Qualité recommandé du béton comprimé et en traction C25/30.

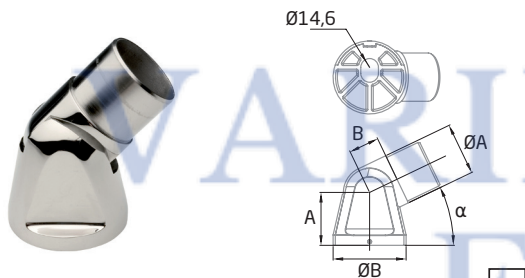

SA-451 AISI-304

CLAVE		ØA	ØB	A	B	α
1380013112SA	2	38.1	60	43.5	25	26-70°
1380013200SA	2	50.8	60	43.5	25	26-70°



BASE DE ACERO INOXIDABLE SUELO - PARED AJUSTABLE.
SATINADO

Posibilidades de anclaje SA-451 / Anchoring possibilities for the SA-451 / Possibilités d'ancrage SA-451

C25/30 Uncracked	C25/30 Cracked / Uncracked
FIS VS 300 T M-12 + DIN 975 + DIN 934 + DIN 125	FIS SB 390 S M-12 + DIN 975 + DIN 934 + DIN 125

* Cracked / Uncracked
Hormigón Traccionado / Hormigón Comprimido
Béton comprimé / Béton en traction

Instalación / Installation / Installation

SA-451

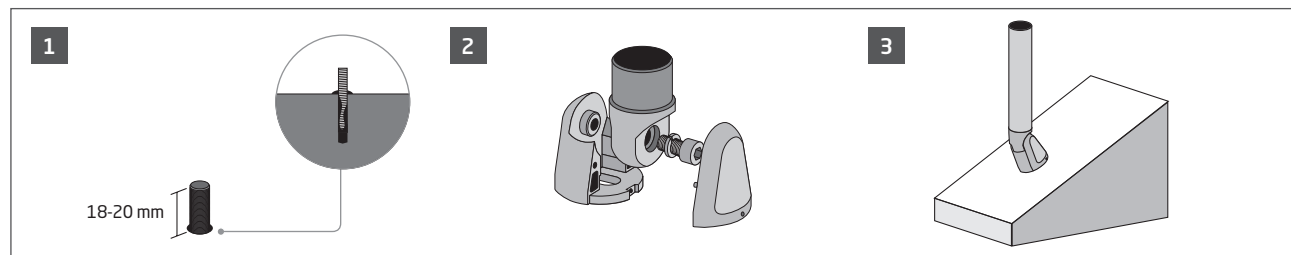

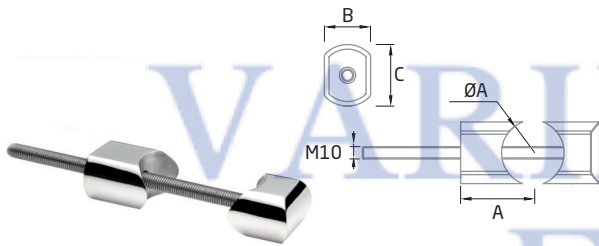

SL-1120 AISI-304

CLAVE		ØA	A	B	C
1380015112SA	* 1 kit	38.1	51	25	30
1380015200SA	* 1 kit	50.8	57	30	40



* 1 kit: 2pcs

SOPORTE LATERAL DE ACERO INOXIDABLE PARA BARANDAL.
SATINADO

Posibilidades de anclaje SL-1120 / Anchoring possibilities for the SL-1120 / Possibilités d'ancrage SL-1120

C25/30 Uncracked	C25/30 Cracked / Uncracked
FIS VS 300 T M-10	FIS SB 390 S M-10

* Cracked / Uncracked
Hormigón Traccionado / Hormigón Comprimido
Béton comprimé / Béton en traction

Instalación / Installation / Installation

SL-1120

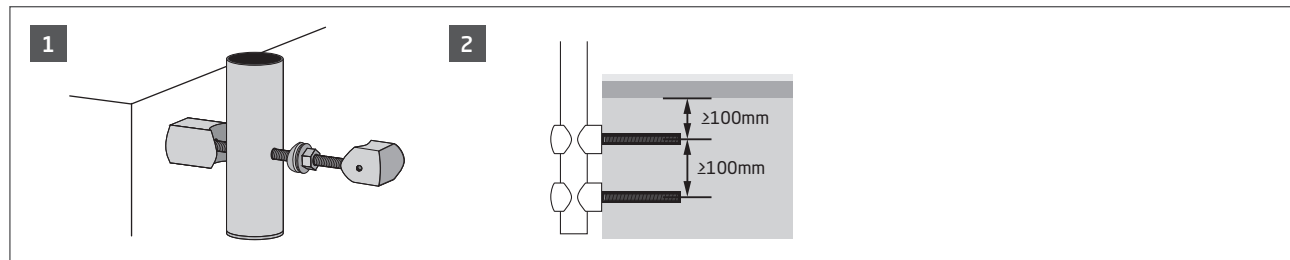

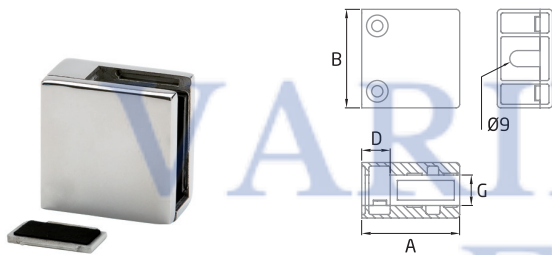

CC-724 AISI-304

CLAVE	A	B	D	G
4	45	45	16	(6-10.76)

DIN-912 M-8 L-20
RG MI M-8

1380010SA

CONECTOR GRAPA CON BASE PLANA PARA VIDRIO DE 8-10MM. SATINADO

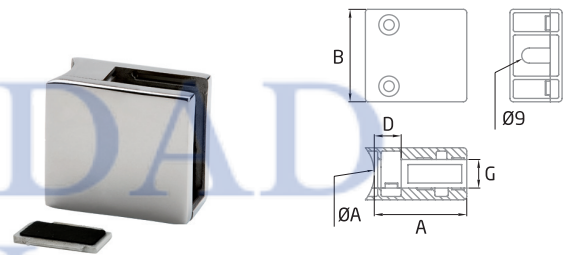

CC-725 AISI-304

CLAVE	øA	A	B	D	G
4	50.8	45	45	16	(6-10.76)

DIN-912 M-8 L-20
BR-2011 M-8

1380011200SA

CONECTOR GRAPA CON BASE CURVA PARA VIDRIO DE 8-10MM. SATINADO

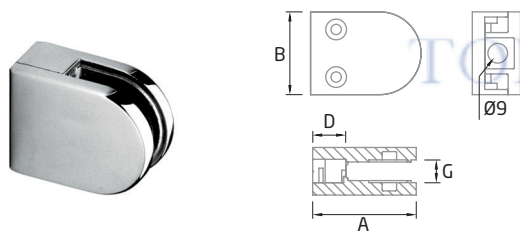

CC-700 AISI-304

CLAVE	A	B	D	G	
1380029SA	4	50	40	16	8-10
1380030SA	4	50	40	16	10-12

DIN-912 M-8 L-20
RG MI M-8

CONECTOR GRAPA PLANO.
SATINADO

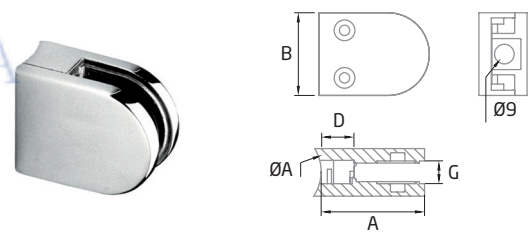

CC-701 AISI-304

CLAVE	øA	A	B	D	G	
1380031112SA	4	38.1	50	40	16	8-10
1380031200SA	4	50.8	50	40	16	8-10
1380032112SA	4	38.1	50	40	16	10-12
1380032200SA	4	50.8	50	40	16	10-12

DIN-912 M-8 L-20
BR-2011 M-8

CONECTOR GRAPA CURVO.
SATINADO

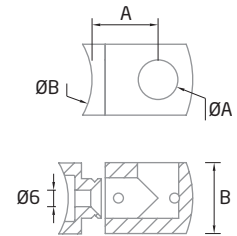
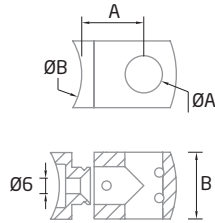

ST-320 AISI-304

SATIN

CLAVE		ØA	ØB	A	B
1380014112SA	4	12.7	38.1	20	21
1380014200SA	4	12.7	50.8	20	21

ST-322 AISI-304

SATIN

CLAVE		ØA	ØB	A	B	L/R
1380023112SA	4	12.7	38.1	20	21	L
1380023200SA	4	12.7	50.8	20	21	L
1380024112SA	4	12.7	38.1	20	21	R
1380024200SA	4	12.7	50.8	20	21	R

DIN-7991 M-6 L-25

BR-2011 M-6



DIN-7991 M-6 L-25

BR-2011 M-6



CONECTOR A POSTE DE ACERO INOXIDABLE BASE CURVA. SATINADO

CONECTORES FINALES IZQUIERDOS Y DERECHOS BASE CURVA. SATINADO

VARIEDAD EN HERRAJES

TOLUCA

Instalación / Installation / Installation

ST-320 / ST-322

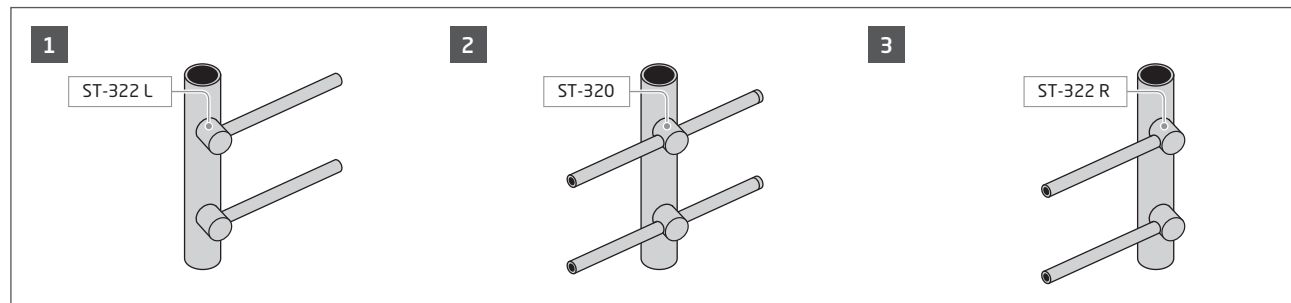



SC-800 AISI-316

	ØC	B
2	4-5 mm	112

BA SATIN

BR-2011 M-6

Tensor.
Tensioner.
Tendeur.



1380025SA

CONECTOR TENSOR LARGO.
SATINADO

SC-801 AISI-316

	ØC	B
2	4-5 mm	71

BA SATIN

BR-2011 M-6

Terminal.
Terminal.
Terminaison.



1380026SA

CONECTOR TENSOR CORTO.
SATINADO

TOLUCA



7 + 7 + 0 semi-flexible

RP-1460

ØC	L
4	Consultar / Inquire / Consulter

138002700

CABLE TENSOR INOXIDABLE 316 DE 4MM (50MTS).

Instalación / Installation / Installation

SC-800 / SC-801

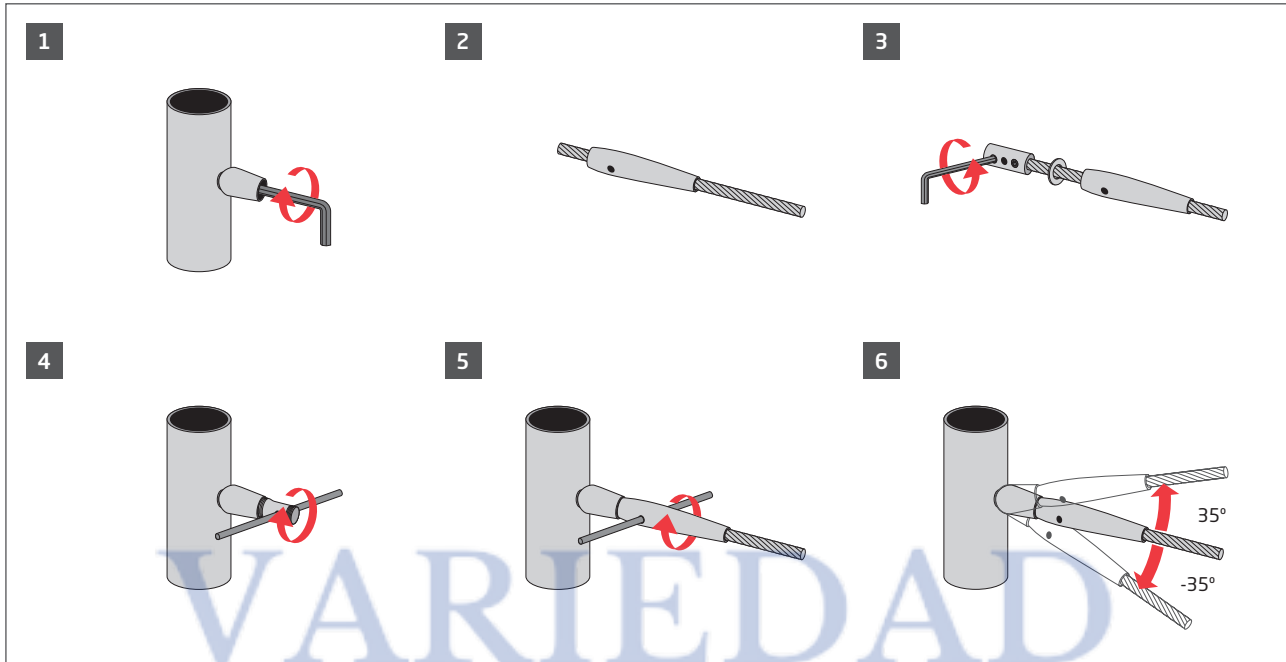

 Ver video de instalación en / Watch installation video at / Voir video d'installation à www.comenza.com

Recomendaciones / Recommendations / Recommendations

Cable Recomendado.
Recommended wire.
Câble recommandé.



7+7+0 semi-flexible

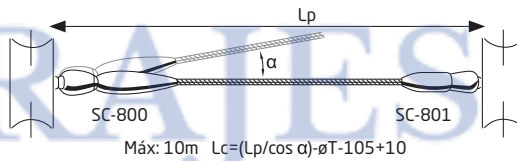

Lc: Longitud del cable / Cable Length / Longueur câble

Lp: Longitud entre centros de pilares / Length between pillar centers / Longueur entre les centres des piliers

øT: ø tubo / ø tube

(Los datos reflejados están basados en ensayos realizados con cálculo elementos finitos y verificados en nuestras instalaciones con ensayos físicos. Es responsabilidad del usuario establecer la idoneidad de la información facilitada con el uso particular que vaya a realizar del producto)

(The data indicated are based on tests conducted by finite element calculation and checked at our facilities with physical tests. The user is responsible of determining the adequacy of the information provided to the particular use of the product)

(Les informations présentes s'appuient sur des tests réalisés par calcul par éléments finis et vérifié par au sein de nos installations par de essais physique. Il incombe à l'utilisateur de définir le bien fondé de l'information fournie et de la recouper en fonction de l'usage qu'il fera lui-même du produit)

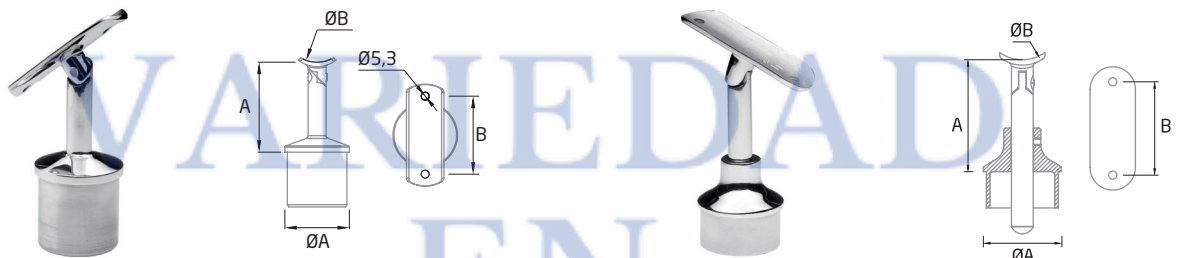

SA-404 AISI-304

CLAVE	ØA	ØB	A	B	E*	
1380008112SA	2	38.1	50.8	55	48	1.5
1380008200SA	2	50.8	50.8	65	60	1.5

SA-420 (BG-R) AISI-304

CLAVE	ØA	ØB	A	B	E*	
1380012200SA	2	50.8	50.8	30-100	61.5	1.5



SOPORTE AJUSTABLE DE ACERO INOXIDABLE.
SATINADO

1380012200SA
SOPORTE AJUSTABLE DE ACERO INOXIDABLE.
SATINADO

TOLUCA

Instalación / Installation / Installation

SA-420 (BG-R)

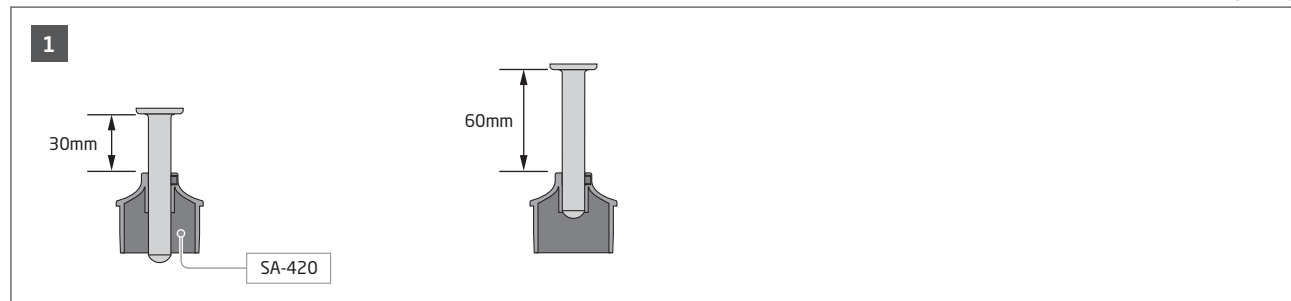

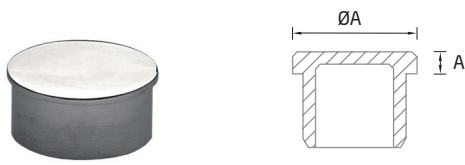

TF-502 AISI-304

SATIN

CLAVE		ØA	A	E*
1380009012SA	2	12.7	2	1
1380009112SA	2	38.1	2	1.5
1380009200SA	2	50.8	2	1.5



TF-505 AISI-304

SATIN

CLAVE		ØA	A	E*
1380036112SA	2	38.1	8	1.5
1380036200SA	2	50.8	12	1.5



TAPA PLANA DE ACERO INOXIDABLE.
SATINADO

TAPA CURVA DE ACERO INOXIDABLE.
SATINADO

VARIEDAD EN HERRAJES

TOLUCA

Instalación / Installation / Installation

TF-502

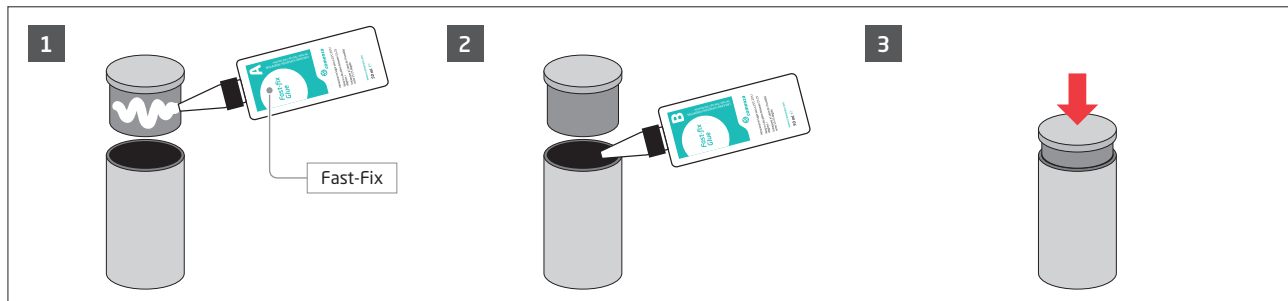

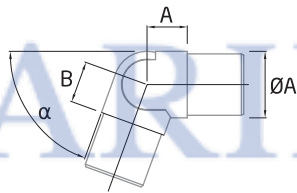

New!

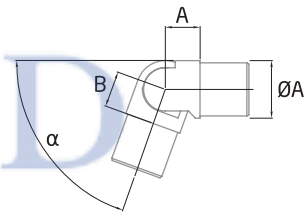

SA-406 AISI-304

CLAVE		ØA	A	B	E*	α
1380007012SA	4	12.7	8	8	1	0-70°
1380007112SA	2	38.1	23	23	1.5	0-70°
1380007200SA	2	50.8	32	32	1.5	0-70°

CONECTOR REGULABLE PARA PASAMANOS DE ACERO INOXIDABLE REDONDO. SATINADO

*Este producto será sustituido por la clave **SA-409** con regulación angular de 0-90°.

SA-409 AISI-304

CLAVE		ØA	A	B	E*	α
1380046012SA	4	12.7	8	8	1	0-90°
1380046112SA	2	38.1	23	23	1.5	0-90°
1380046200SA	2	50.8	32	32	1.5	0-90°

CONECTOR REGULABLE PARA PASAMANOS DE ACERO INOXIDABLE REDONDO, HASTA 90°. SATINADO

*Solo disponible en presentación de 38.1mm (1 1/2"), las medidas restantes se encuentran en desarrollo.

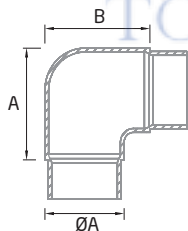

CT-200 AISI-304

CLAVE		ØA	A	B	E*
1380003112SA	2	38.1	55	55	1.5
1380003200SA	2	50.8	60	60	1.5



CODO A 90° PARA PASAMANOS DE ACERO INOXIDABLE REDONDO. SATINADO

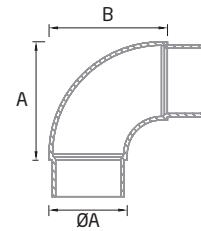

CT-201 AISI-304

CLAVE		ØA	A	B	E*
1380004112SA	2	38.1	55	55	1.5
1380004200SA	2	50.8	60	60	1.5



CODO A 90° PARA PASAMANOS DE ACERO INOXIDABLE REDONDO. SATINADO

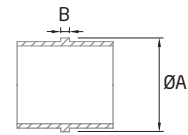
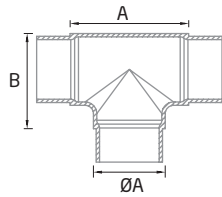

CT-202 AISI-304



CLAVE		ØA	A	B	E*
1380005112SA	2	38.1	70	55	1.5
1380005200SA	2	50.8	69	60	1.5

CT-207 AISI-304



CLAVE		ØA	B	E*
1380006112SA	2	38.1	4	1.5
1380006200SA	2	50.8	4	1.5

CODO RECTO DE ACERO INOXIDABLE TIPO T.
SATINADO

UNIÓN DE ACERO INOXIDABLE PARA TUBO.
SATINADO

VARIEDAD EN HERRAJES

TOLUCA



Sistema / System / Système
Handrail: Round

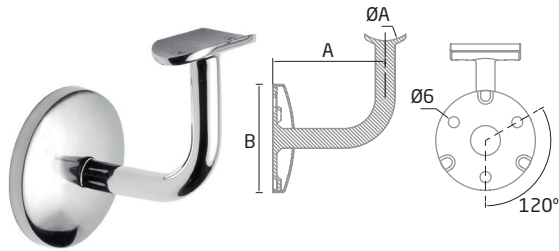

ST-353 AISI-304

SATIN

	ØA	A	B
2	50.8	69	66

BR-2012



1380037200SA

CONECTOR A MURO PARA PASAMANOS DE ACERO INOX.
SATINADO

VARIEDAD EN HERRAJES

Instalación / Installation / Installation

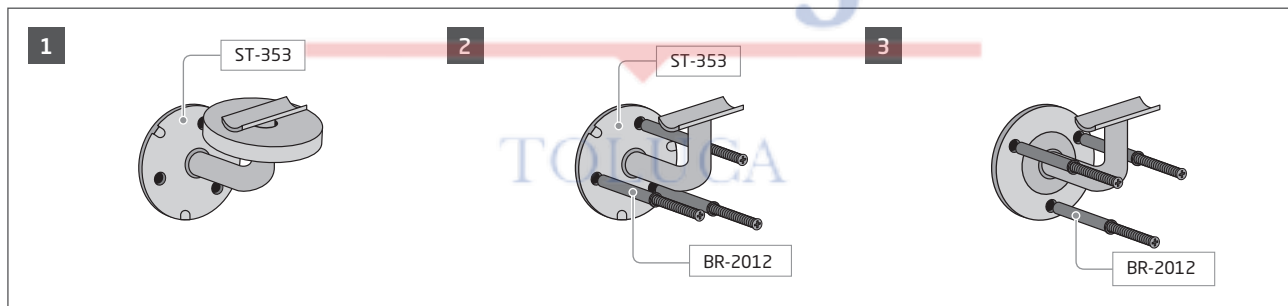

El soporte está diseñado para posibilitar su fijación en un solo tiempo usando tacos premontados. Una vez finalizado el montaje y asegurado el soporte sobre la superficie de apoyo, se fija el embellecedor ejerciendo una pequeña presión sobre la base, quedando la goma oculta en su interior. [img.1]

Pasos de instalación con ST-353:

1. Taladrado de la pared
2. Colocación de pieza
3. Fijar el soporte a la pared con el taco premontado [img.2]

Pasos de instalación en soportes convencionales:

1. Taladrado de la pared
2. Colocación del tirafondo
3. Colocación de la pieza
4. Fijar el soporte [img.3]

This product has been designed to enable its fixing at once using nylon hammer drive anchor. Once the assembly is finished and the support is fastened on the support surface, the cover is placed pressing slightly on the base, and the rubber rests hidden inside. [img.1]

Installation steps with ST-353:

1. Drill the wall.
2. Place the ST-353.
3. Fix the support to the wall with the preassembled anchor. [img.2]

Installation steps with traditional supports:

1. Drill the wall.
2. Place the lag bolt.
3. Fix the piece.
4. Fix the support. [img.3]

Ce support a été conçu pour faire possible la fixation d'un coup d'ancrages pré-assemblés du type de cheville en plastique. Quand le montage est fini et le support bien fixé à la surface d'appui, on fixe l'enjoliveur en exerçant une petite pression sur la base, en restant la caoutchouc torique cache dans l'intérieur. [img.1]

Installation avec le support ST-353:

1. On perce le mur.
2. On place la ST-353
3. On fixe le support au mur avec l'ancrage pré-assemblé. [img.2]

Installation avec un support traditionnel:

1. On perce le mur.
2. On place la vis tire-fond.
3. On place la pièce.
4. On fixe le support. [img.3]

Brico

VARIEDAD
EN
HERRAJES





Fast-Fix Glue A+B (50+50ml) *

1 kit

Duración aproximada / Estimated duration / Duration approximative

ø50,8	ø43	ø38,1	ø20	ø12
40	50	60	120	150

Características FAST-FIX GLUE

- Envase bicomponente A+B
- Velocidad de curado:
Curado inicial 30 segundos / 50% sujeción 45 min / 100% sujeción 24h.
- Cubre holguras de hasta 0,3 mm
- Cantidad: 50+50ml
- Temperatura de conservación: 15°-25°

FAST-FIX GLUE characteristics:

- A+B Bi-component packaging
- Drying speed:
Initial curing 30 seconds / 50% bonding 45 min / 100% bonding 24h.
- Provides coverage for gaps up to 0,3 mm.
- Quantity: 50+50ml
- Storage temperature: 15-25°

Caractéristiques FAST-FIX GLUE

- Flacon bicomposant A+B.
- Vitesse de séchage:
Fixation initiale 30 secondes / 50% fixation 45 min / 100% fixation 24h.
- Remplissage de dégagements jusqu'à 0,3 mm
- Quantité: 50ml + 50ml
- Température de stockage: 15-25°

13801000
ADHESIVO FAST - FIX A + B.

VARIEDAD
EN
HERRAJES



CLEAN+ (500ml) *

1



STAIN ZERO (500ml) *

1

13801010
LIMPIADOR DE ACERO INOXIDABLE 500ML.

13801020
QUITAOXIDO 500ML.

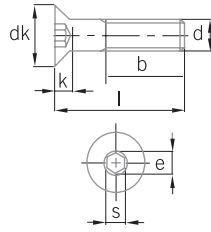

DIN-7991

Qlty.	d	L	dK	K	e	S	B	
50	A2/A4	M-6	25	12	3.3	4.7	4	18
50	A2/A4	M-10	20	20	5.5	7	6	26

M-6	Serie	Ref.
	ST	ST-320, ST-322

M-10	Serie	Ref.
	SV	SV-1302

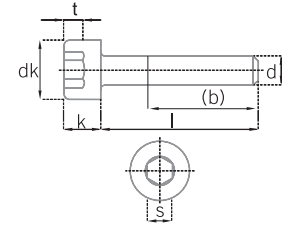

DIN-912

Qlty.	d	L	dK	Kmax	S	
50	A2/A4	M8	20	13	8	6

Serie	Ref.
CC	CC-700, CC-701, CC-724, CC-725

13800200
TORNILLO CABEZA PLANA.

138002100
TORNILLO.

VARIEDAD EN HERRAJES



BR-2011

CLAVE	Qlty.	M
138001800	50	A2/A4 M6
138001900	50	A2/A4 M8

M-6	Serie	Ref.
	SC	SC-800, SC-801
	ST	ST-320, ST-322,

M-8	Serie	Ref.
	CC	CC-700, CC-701, CC-724, CC-725

TUERCA REMACHABLE.

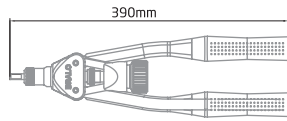

TR-308

Ø mm	Aluminio Aluminium	Acero Iron / Acier	Inox Steel
M-4	✓	✓	✓
M-6	✓	✓	✓
M-8	✓	✓	✓

* Remachadora tuerca remachable
Riveting tools for rivet nuts
Riveteuses pour écrou à rivet aveugle

BR-2030

Icon	Ø
1	45-50

Ø45-50	Serie	Ref.
	CC	CC-775 D.50, CC-735
	SA	SA-423
	ST	ST-314, ST-315

VARIEDAD
EN
HERRAJES

138010300

REMACHADORA.

138010400

HERRAMIENTA DE FIJACIÓN PARA DIÁMETRO DE 50MM (CC775).



BR-2031

Icon	Ø
1	11 a 60

Ref.
CC-780, CC-781, CC-782, CC-783

138010500

PINZA PARA INSTALACIÓN DE HERRAJE CC-780 Y CC-781.



Info

Los datos técnicos mostrados en este catálogo sólo tienen carácter informativo y por lo tanto los productos originales pueden diferir ligeramente de las medidas e ilustraciones fotográficas.

Comenza se reserva el derecho a realizar cambios y mejoras en los productos mostrados en este catálogo siempre que lo estime oportuno.

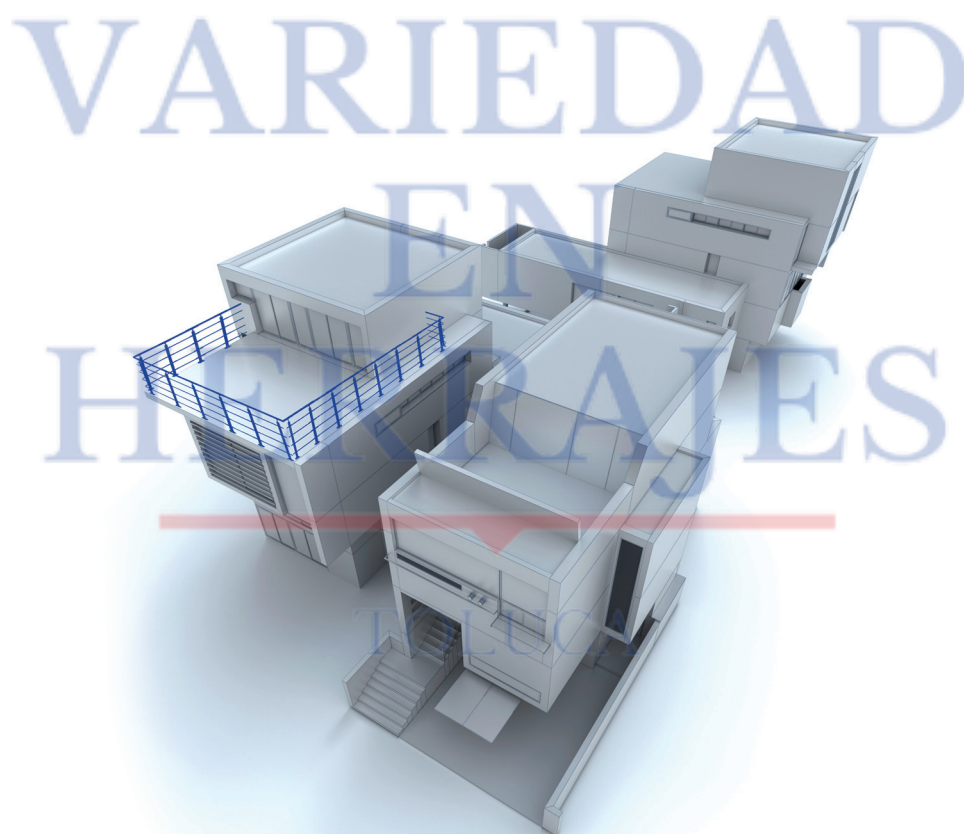



HERRALUM®

líder en herrajes para aluminio y vidrio

VARIEDAD
EN
HERRAJES

TOLUCA

Herralum Industrial SA de CV

Calle 4 #10557
Parque Industrial El Salto
El Salto, Jalisco - CP 45680

Tel. 01-33-3666 0312
Fax. 01-33-3666 0442

www.herralum.com
herralum@herralum.com

Distribuidor exclusivo para México:

